



Model 31777-0000 12/24 VDC Pump Controller Variable Speed Drive (VSD)

INSTALLATION & SERVICE INFORMATION

SMOOTH-FLOW™

WATER SYSTEM CONTROLLER

Variable Speed Drive (VSD) converts everyday pumps into sensor-controlled pumps that automatically adjust in real time to changes in pressure. As less flow is required, the pump motor slows down to provide a smooth and pulsation-free performance.

FEATURES

- Provides smooth and quiet water flow without pulsation (water hammer)
- Eliminates temperature variation
- Eliminates need for space consuming accumulator tank
- Works on most water pressure pumps rated 3-12 amps
- Easy-to-install; hose and fittings included
- Runs on 12 or 24 VDC input

HOW IT WORKS

The controller automatically measures the pressure at which the pump's pressure switch opens. It uses this measurement to determine an optimal running pressure for the given pump, and stores the value in its memory for consistency between power cycles.

Compatible Pump Requirements:

- Diaphragm pumps with 3, 4 or 5 pumping chambers.
- 12 or 24 VDC.
- 12 amp maximum at 12 Volts.
- 6 amp maximum at 24 Volts.
- 3 amp minimum pump rating.
- MPU pressure switch rating: 30 to 65 psi.
- Motor voltage must match system voltage.
- Not compatible with Flojet 4405 and Jabsco 31295/31395 Series pumps.



SPECIFICATIONS

Model number:31777-0000

Voltage:12 or 24 VDC input

Amps:12 amps at 12 V
6 amps at 24 V

Flow Range:Depends on pump

Size: ... 4.7"(115 mm) x 3.4"(85 mm)x 3.0"(73.5 mm)

Weight:8.2 Oz (0.23 Kg)

DIMENSIONAL DRAWING

Dimensions in inches (millimeters)

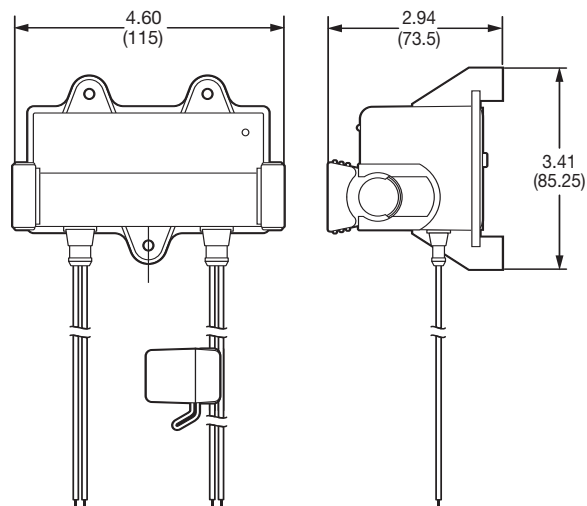

WARNING

This product is to be used for potable water system applications only. Use with any other medium, including particularly hazardous, flammable, caustic or corrosive substances, could result in damage to the unit, the surrounding environment and injury to persons or property, including possible exposure to hazardous substance.

Kit Inventory

NOTE:
Loosen Hose
Clamp and
Rotate Fitting
to Facilitate
Installation

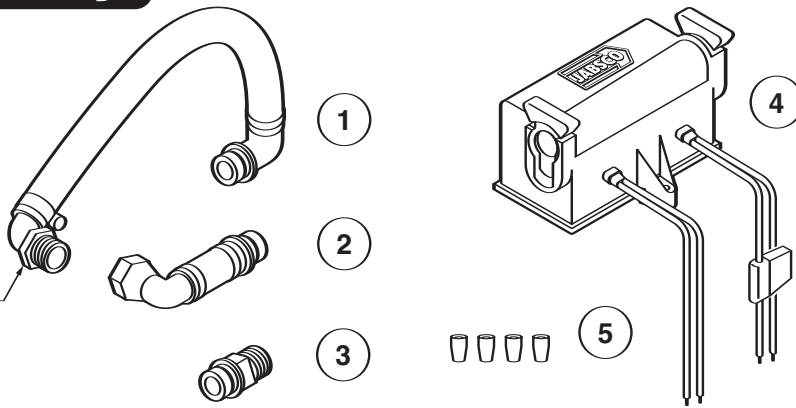

PARTS KEY

1. Water System Hose
2. Pump Elbow Hose
3. Quick-Connect Fitting
4. Universal VSD Unit
5. Wire Nuts

Tools Required



• Screwdriver



• Wire Cutters

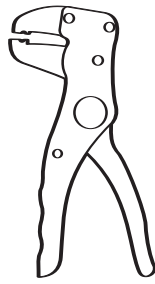

• Wire Strippers

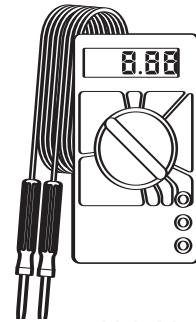

• Volt Meter

In addition to basic tools, you may need a towel or rag during installation, as some water may drain from the hose lines when opened.

Location/Pre-install

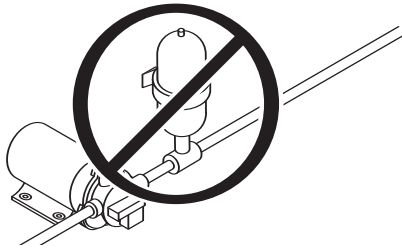

- Remove Accumulator Tank (if installed). System may not operate properly if there is an accumulator tank installed anywhere in the system.
- Mount the VSD Module as close as possible to the pump discharge. (Kit is set up to mount directly to pump discharge)

EXISTING INSTALLATIONS

- When restoring an existing installation to operation, open all faucets and follow steps in the Auto-Alignment section.

ELECTRICAL INSTALLATION TIPS

- Wiring can be shortened as needed or left as-is.
- Be sure to bundle wiring, such as with a zip tie, to avoid snagging other objects.

If the system fails to operate, check electrical connections, main fuse or breaker, and indicator light on front panel of controller. See Troubleshooting Section for more information.



WARNING



Avoid contact with the black metal plate on the rear of the unit, its temperature may exceed 176°F (80°C).

Plumbing

- Turn off power to the pump.
- Shut off water supply to pump.
- Open faucets and low-point drains to relieve pressure in lines.
- Disconnect existing hose connection from pump outlet (see Figure 1).
- Connect pump discharge hose line to either line port in the controller. Make sure the snap-fit gate fittings on the controller snap securely into place when attaching hose lines (see Figure 2 as example).
- Connect water system hose line to remaining line port of pump controller (see Figure 2 as example).

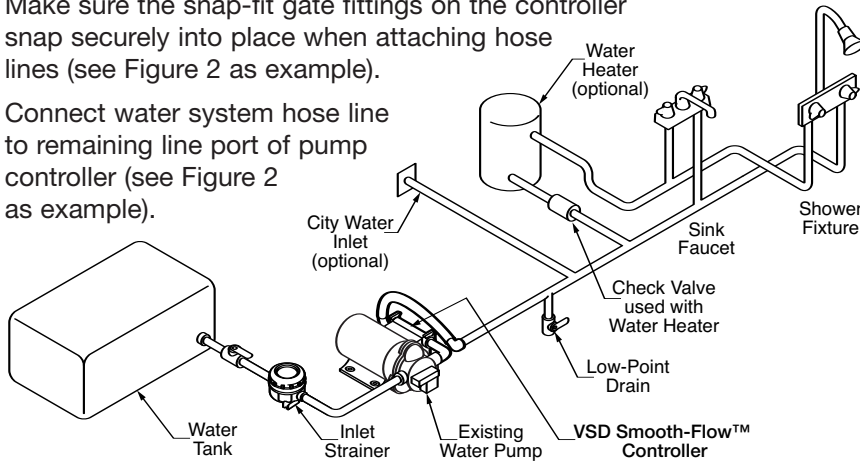

Figure 1

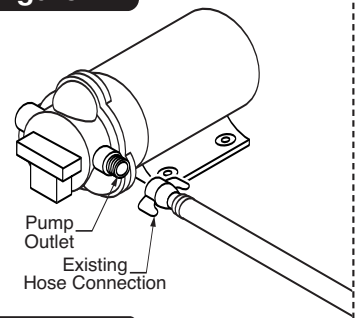
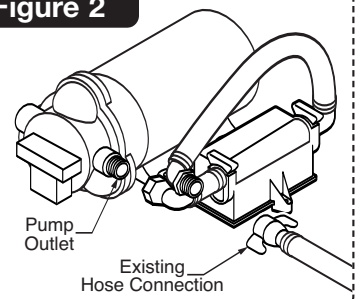
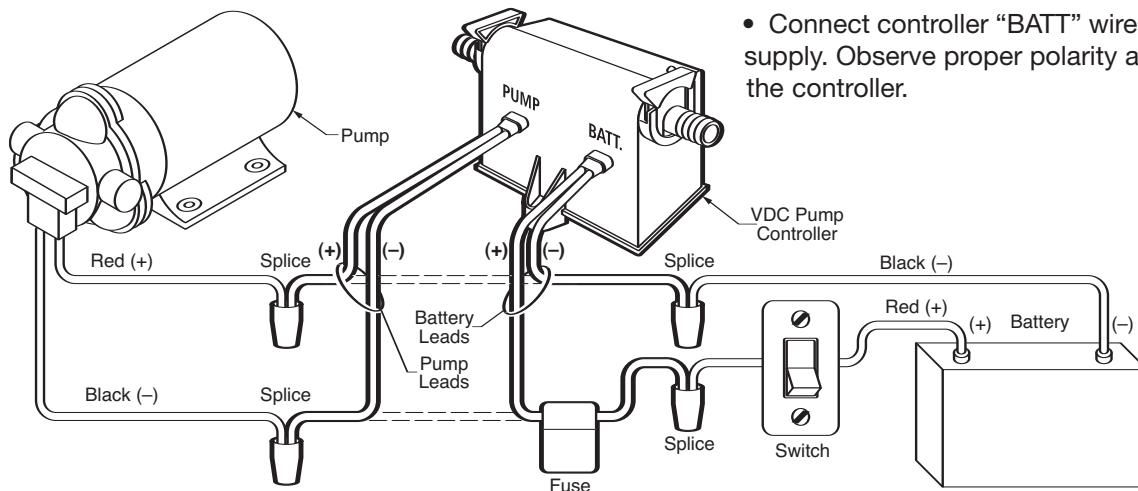

Figure 2



Wiring

- Disconnect the power to the pump.
- Connect pump wiring to the “PUMP” leads of the controller. Observe proper polarity as indicated on the controller.
- Connect controller “BATT” wires to the power supply. Observe proper polarity as indicated on the controller.



Auto-Alignment

- Turn on power to the pump circuit.
- Allow water flow to purge air from the lines. System must be completely purged.
- When air has been purged and a smooth flow is reached, close each valve, one valve at a time. Gradually close the last valve.
- The control will auto-align itself to the pump in a few seconds. The system is then ready to use.

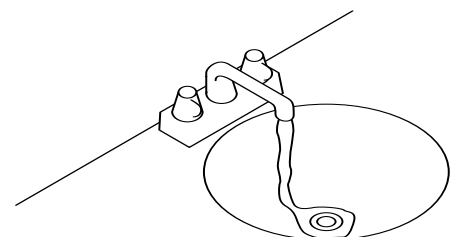

TROUBLESHOOTING CHART

Symptom	Possible Cause(s)	Corrective Action
Pump Does Not Run	Pump may be overheated Fuse or breaker may be open. An error condition may exist	Allow pump to cool Check fuse or breaker See "Error Condition" below
Pump Runs Intermittently When Not In Use	A leak in the plumbing or pressure may be bleeding off through the pump	Check for leaks in the plumbing. Briefly open a faucet all the way and then sharply close it. This may clear out debris from the pump and allow it to seal correctly inside.
Switch Cycling	System needs re-alignment	While the pump is cycling, turn power off for at least 10 seconds, then turn the power back on. The controller will gradually re-align to a reduced operating pressure.
System Runs at Very Low Pressure	The control unit has not completed pressure auto-alignment.	Ensure that the system is fully charged with water (purge air), then ensure all valves are closed.
Pump Motor Hums	Pump mounting surface	None. Some hum occurs with normal operation and is expected.

ERROR CONDITION

This unit has an error code system built in. The small light located on the front right side of the unit will indicate:

- 1 Blink – Pressure switch value too low (under 20 PSI)
- 2 Blinks – Pressure switch value too high (over 70 PSI)
- 3 Blinks – Maximum run time exceeded (20 minutes)

To correct any of these modes, cycle power off for at least 10 seconds, then turn back on. The control will not work on pumps where the switch value is at or below 20 psi or above 70 psi.



PRODUCT WARRANTY

One Year Limited Warranty is available on request. Opening the unit voids the warranty.

Note: The wiring diagrams are offered for reference. Position of the pump, control and power supply wires and hoses should be placed so as not to interfere with any components for operation of the vessel.

CONTROL PORT FITTINGS AVAILABLE

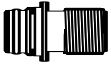
Snap-In Port System

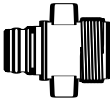
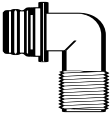
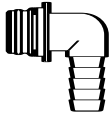
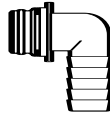
						
30649-1000	30654-1000	30653-1000	30650-1000	30655-1000	30651-1000	30642-1000
SNAP-IN PORT x 1/2" MALE QEST. STRAIGHT	SNAP-IN PORT x 1/2" HOSE BARB STRAIGHT	SNAP-IN PORT x 3/4" HOSE BARB STRAIGHT	SNAP-IN PORT x GARDEN HOSE STRAIGHT	SNAP-IN PORT x 1/2" MALE QEST. 90° ELBOW	SNAP-IN PORT x 1/2" HOSE BARB 90° ELBOW	SNAP-IN PORT x 3/4" HOSE BARB 90° ELBOW

For technical advice or service please take your pump into your local pump service center.
To order pump or parts or for pricing please go to the following links :

[Jabsco Pumps Home >>](#)

[Jabsco Pumps stock list >>](#)