



a xylem brand

SELF-PRIMING PUMPS

FEATURES

- Pump Type:** 30510-4XXX Close Coupled
30510-2XXX Pump Head
- Body:** 316 Stainless Steel
- Impeller:** Neoprene, Nitrile, Viton* or EPDM
- Shaft Seal:** Mechanical, Carbon-on-Ceramic or Tungsten Carbide; Nitrile.
- Ports:** 3/4" NPT Internal
- Shaft:** 316 Stainless Steel
- Motor:** 115 Vac, Single Phase, 60 Hz, 3/4 HP, 1750 RPM, TEFC, C-Face, 56C Frame, Overload Protected, Capacitor Start.
- Weight:** 30510-4XXX 36.0 lb (16,3 kg) Approx.
30510-2XXX 7.5 lb (3,4 kg) Approx.

⚠ WARNING



Explosion hazard. Motor can spark. Explosion & death can occur. Do not use where flammable vapors are present.

APPLICATIONS

INDUSTRIAL: Circulating and transferring, velocity-mixing, pumping machine tool coolants, spill return, sump drainage, chemicals, pharmaceuticals, soap, liquors, ink, dyes, alcohol, dilute acids, tanning liquors, glycerine, brine, etc.

PHARMACEUTICAL: Processing medicines, lotions and preparations. Filtering pharmaceutical solutions. Filling line supply pump.

PAPER PROCESSING: Transferring and applying starches, sizes, etc. Circulating and processing wood pulp slurries.

FOOD, BEVERAGE & DAIRY: Transfer brines, vinegar, syrups during processing, liquids containing solids in suspension such as chopped tomatoes, nuts, etc. Removal of distillery wort and brewery slop. Processing viscous materials such as peanut butter, mayonnaise, ketchup, honey, etc. (low speed). Pumping whiskey, wine, rums, juices and ciders.

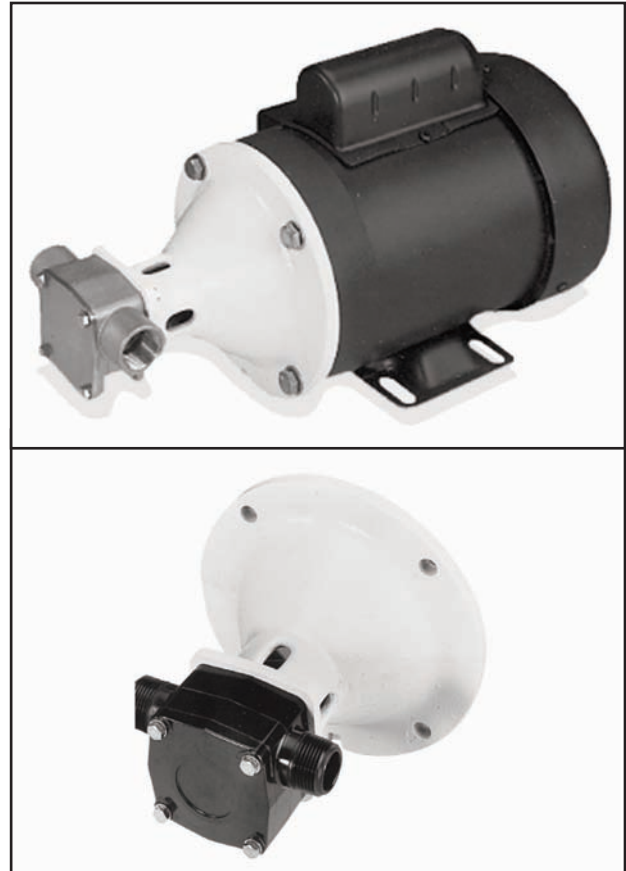

Model 30510-4XXX, 30510-2XXX

VARIATIONS AVAILABLE

MODEL	DESCRIPTION
30510-4001 30510-2001	Standard Pressure, Neoprene Impeller, Carbon Seal
30510-4003 30510-2003	Standard Pressure, Nitrile Impeller, Carbon Seal
30510-4004 30510-2004	Standard Pressure, Viton Impeller, Carbon Seal

⚠ WARNING



Explosion hazard. Do not pump gasoline, solvents, thinners or other flammable liquids. To do so can cause an explosion resulting in injury or death.

OPERATING INSTRUCTIONS

1. **INSTALLATION** – Pump may be mounted in any position. The rotation of the pump shaft determines the location of the pump's intake and discharge ports. (Refer to dimensional drawing.) Pump is normally assembled at factory for clockwise rotation (looking at end cover). If counter clockwise rotation is desired, follow steps 1 and 2 of disassembly and step 7 of assembly instructions to change direction of impeller blade deflection under cam.
2. **MOTOR SELECTION** – Pump head is designed to fit a 56C Frame NEMA C-Face motor. Motor should be rated 3/4 horsepower at 1750 RPM with a service factor of one. Due to high bearing loads, motor should be ball bearing equipped with the front bearing locked against axial movement. Motor should be capacitor start and foot mounted.
3. **SPEEDS** – 100 RPM to the maximum shown in the performance curves. For longer pump life, operate at lowest possible speeds. Lower speeds are required for viscous liquids. Consult the factory for proper speeds and horsepower requirements.
4. **SELF-PRIMING** – Primes at low or high speeds. For vertical dry suction lift of 10 feet (neoprene/nitrile) – 6 feet (viton/EPDM), a minimum of 860 RPM is required. Pump will produce suction lift up to 22 feet when wet.
BE SURE SUCTION LINES ARE AIRTIGHT OR PUMP WILL NOT SELF-PRIME.
5. **DISCHARGE** – When transferring liquids further than 25 feet, use one size larger discharge line than discharge port size.
6. **RUNNING DRY** – Unit depends on liquid pumped for lubrication. DO NOT RUN DRY for more than 30 seconds. Lack of liquid will damage the impeller and seal.
7. **CHEMICAL COMPATIBILITY** – Consult the Chemical Resistance Guide in the JABSCO Industrial Pump Catalog (available upon request from ITT Jabco) or factory for proper body materials and impeller compounds. If corrosive fluids are handled, pump life will be prolonged if pump is flushed with a neutralizing solution after each use or after each work day. A Tungsten Carbide Seal variation is available for pumping liquids that contain abrasives or are highly corrosive.
8. **PRESSURES** – Consult Performance Curve for maximum recommended pressure for pumps in continuous operation. If pressures exceed those shown, consult the factory.
9. **TEMPERATURES** – The operating temperature limits of the pump depend on the impeller compound. The following ranges apply:
Neoprene - 45° to 180° F (7° to 82° C),
Nitrile - 50° to 180° F (10° to 82° C),
Viton - 60° to 180° F (15° to 82° C),
EPDM - 45° to 185° F (7° to 85° C).
10. **IMPELLER TORQUE** – The torque required to initiate rotation of a new impeller in a dry pump body is:
Standard Pressure Impeller (14281-Series):
Forward = 1.5 pounds force - feet
Reverse = 4.3 pounds force - feet
These values may vary slightly due to impeller compounding, blade set, and body material of construction. Consult factory for more information.
11. **SPARE PARTS** – To avoid costly shutdowns, keep a spare JABSCO impeller, seal and O-ring set on hand.

SERVICE INSTRUCTIONS

DISASSEMBLY

1. Remove the four end cover screws. Remove end cover and O-ring.
2. Remove the four screws holding the body to the adapter flange. Slide body, complete with impeller and wearplate, from adapter and shaft.
3. Remove mechanical seal by inserting two screwdrivers behind seal collar, and gently lever collar and seal assembly forward on shaft. Use extreme care not to mar shaft. Remove seal seat and rubber cup from recess in wearplate.
4. Remove the four screws holding the adapter to the motor and remove the adapter.
5. The stub shaft is held in place with set screws and Loctite* RC/680 retaining compound. Extreme care must be taken not to damage the motor shaft and bearings when removing the stub shaft. Heat shaft joint area to facilitate disassembly of set screws and stub shaft from motor shaft. DO NOT EXCEED 300°F when heating joint area. Once joint area has been heated, remove set screws and slide stub shaft from motor shaft.

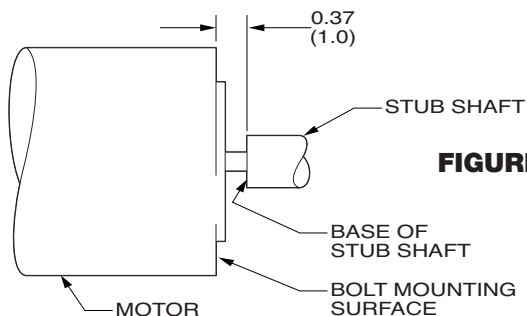

FIGURE 1

ASSEMBLY

1. Liberally apply Loctite RC/680 retaining compound to the motor shaft and slide the stub shaft on, positioning the base of the stub shaft 0.37" from the bolt mounting surface of motor. For clarification, refer to Figure 1 below. Loctite aids in preventing fretting and subsequent shaft failure. Wipe off excess Loctite. Apply Loctite to the two dog point (flat point) set screws, position in the set screw holes aligned with the keyway of the motor shaft and torque to 85 - 90 in. lbs.
2. Replace the adapter on the motor and tighten the four mounting screws to 20 ft. lbs.
3. Replace mechanical seal by sliding spacer onto shaft up to locating shoulder, then smear shaft with light lubricating oil. Push on seal gently until it engages with spacer. Fit rubber cup and seal seat into wearplate.
4. Insert impeller in pump body, fit O-ring in each end of the pump body.
5. Slide body assembly over shaft, position wearplate in housing. Fit body to adapter screws. Torque screws to 20 in. lbs.
NOTE: A gap should be maintained between bearing housing and body.
DO NOT overtighten screws.
6. Fit end cover and end cover screws. Torque screws to 20 in. lbs.
7. **Changing Pump Rotation** (looking at end cover):
 - a. Clockwise Rotation: Insert impeller into pump body with blades bending counterclockwise.
 - b. Counterclockwise Rotation: Insert impeller into pump body with blades bending clockwise.

* Loctite* is a trademark of Loctite Corporation.

KEY	DESCRIPTION	QTY. REQ.	MODEL 30510-4XXX PART NO.	QTY. REQ.	MODEL 30510-2XXX PART NO.
1	Adapter	1	18753-0215	1	18753-0215
2	Body	1	18753-0187	1	18753-0187
3	End Cover	1	18753-0193	1	18753-0193
4	Wearplate	1	18753-0199	1	18753-0199
5	Shaft	1	18753-0209	1	18753-0209
6	Impeller: Standard Pressure - Neoprene Standard Pressure - Nitrile Standard Pressure - Viton Standard Pressure - EPDM	1	14281-0001 14281-0003 14281-0004	1	14281-0001 14281-0003 14281-0004 7614-0002
7	Motor, 3/4 HP, 115Vac, 1Ph, 60Hz, TEFC, C-Face, 56C Frame	1	18753-0219	-	-
8	Seal Spacer:	1	18753-0223	1	18753-0223
9	Seal Seat: Nitrile	1	18753-0233	1	18753-0233
10	Seal Mech: Carbon - Nitrile Carbon - Viton Tungsten Carbide - Nitrile Tungsten Carbide - Viton	1	18753-0241 18753-0242 18753-0243 18753-0244	1	18753-0241 18753-0242 18753-0243 18753-0244
11	O-Ring: Nitrile Viton	2	18753-0261 18753-0262	2	18753-0261 18753-0262
12	Screw Kit: (consists of) Bolts, Hex Hd. 3/8-16 x 1" Screws, Hex Hd. M5 x 16mm Screws, Hex Hd. M5 x 8mm Set Screws, Cup Pt. 1/4-20 x 1/4 Set Screws, Dog Point 1/4-20x 1/2 Washers, Flat 3/8 Washers, Flat M5	1	18753-0278	1	18753-0278

EXPLODED VIEW

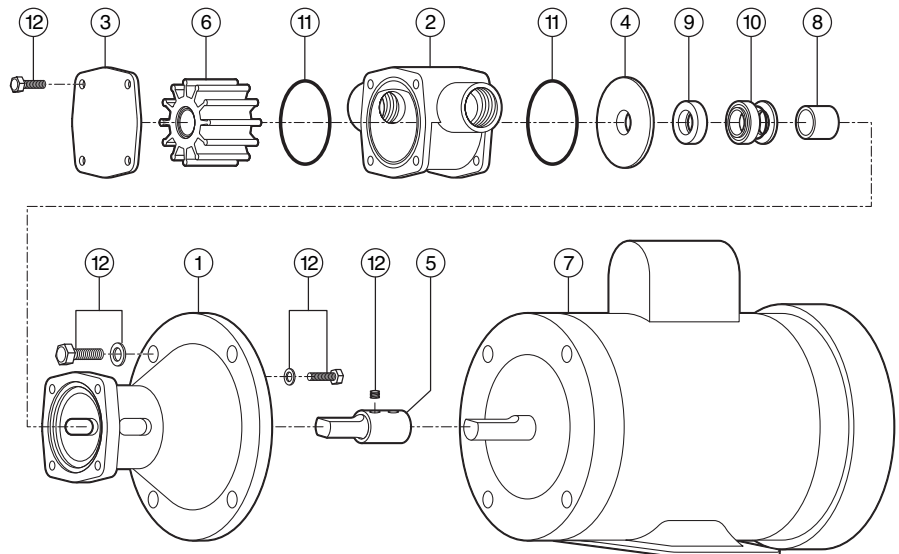

DIMENSIONAL DRAWING

Inches (millimeters)

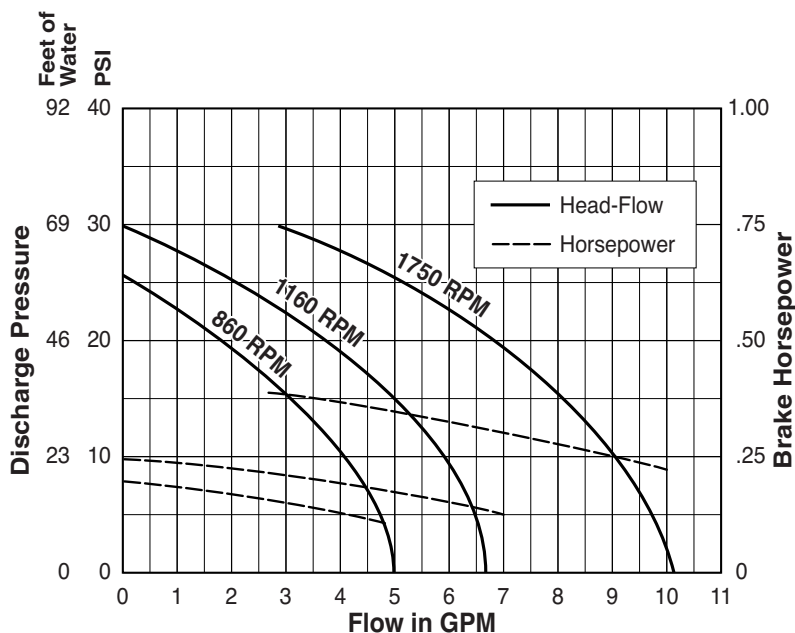
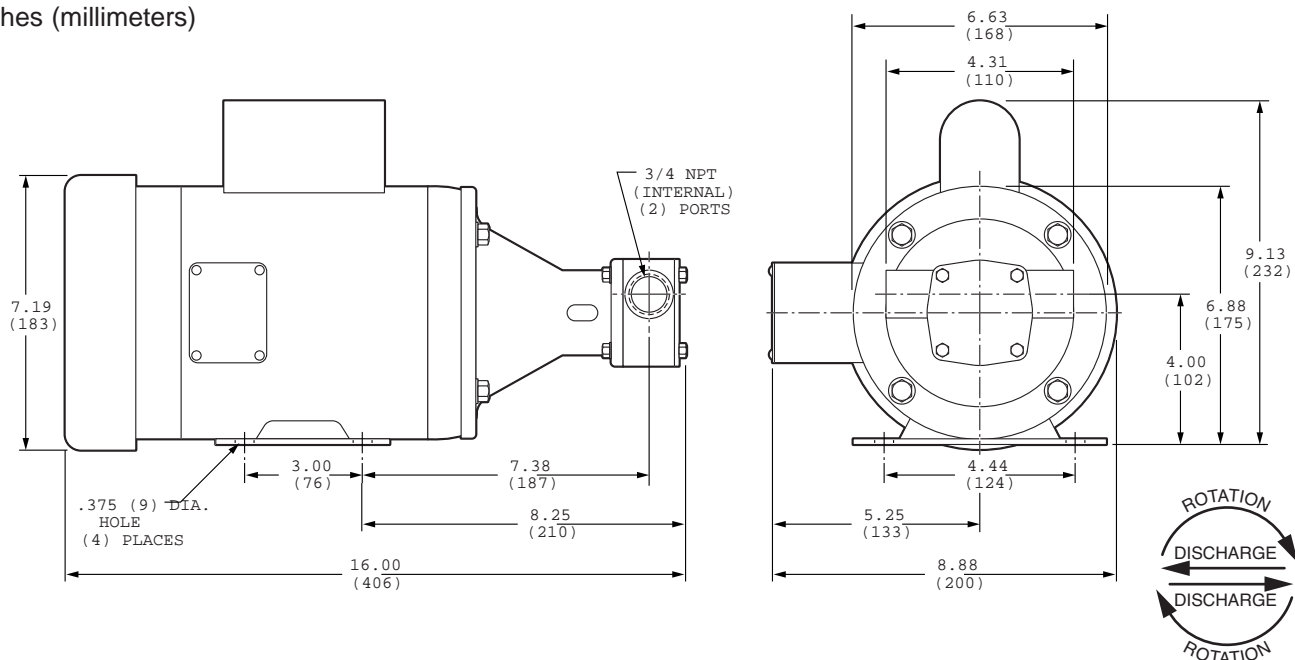

PERFORMANCE CURVES

NOTE: Curve shows approximate head-flow for new pumps with neoprene impeller pumping water. Capacities should be reduced approximately 10% with nitrite impeller.

THE PRODUCTS DESCRIBED HEREIN ARE SUBJECT TO THE JABSCO ONE YEAR LIMITED WARRANTY, WHICH IS AVAILABLE FOR YOUR INSPECTION UPON REQUEST.



a xylem brand