



Model 2620-Series

SELF-PRIMING PUMPS

FEATURES

Body:	Bronze
Impeller:	Neoprene or Nitrile
Shaft:	316 Stainless Steel
Shaft Seal:	Nitrile Lip Type
Bearings:	Sealed Ball Bearings
Ports:	3/8" NPT(f) Internal
Weight:	2-3/4 lb (1.3 kg) Approx.

VARIATIONS AVAILABLE

MODEL NO.	DESCRIPTION
2620-1001	Neoprene Impeller
2620-1003	Nitrile (oil resistant) Impeller

APPLICATIONS

MARINE: Engine Cooling, Pumping bilges, Washdowns, Circulating water in bait tanks, Utility dock side pump.

INDUSTRIAL: Circulating and transferring, Velocity-mixing, Pumping machine tool coolants, Return spill, Sump drainage, Chemicals, Pharmaceuticals, Soap, Liquors, Ink, Dyes, Alcohol, Various acids, Tanning liquors, Glycerine, Brine, etc.

OPERATING INSTRUCTIONS

- INSTALLATION** – Pump may be mounted in any position. Intake and discharge ports are determined by the direction of shaft rotation (refer to Dimensional Drawing). Before installing, turn the pump shaft in the direction of the operating rotation.
- DRIVE** – Belt or Direct with flexible coupling. If pulley or coupling is a press fit on shaft, remove end cover and impeller and support shaft at impeller end while pressing drive on shaft.
Belt Drive – Overtight belt load will reduce pump bearing life.
Direct Drive – Clearance should be left between drive shaft and pump shaft when installing coupling.

WARNING

Injury hazard. Exposed pulleys and belts can cause injury. Install shield around pulleys and belts. Stay clear while machinery is operating.

Always mount and align pump and drive shaft before tightening the coupling set screw.

- SPEEDS** – 100 RPM to the maximum shown in the performance table. Consult the factory for operation at speeds above those shown. For longer pump life, operate at lowest possible speeds.



Model 2620-Series

- SELF-PRIMING** – Primes at low or high speeds. For vertical lift of 10 feet (3.0m), a minimum of 800 RPM is required. Pump will produce suction lift of up to 22 feet (6.7m) when wetted. **BE SURE SUCTION LINES ARE AIRTIGHT OR PUMP WILL NOT SELF-PRIME.**
- RUNNING DRY** – Unit depends on liquid pumped for lubrication. **DO NOT RUN DRY** for more than 30 seconds. Lack of liquid will damage the impeller.
- NOTICE** – Do not pump light fraction petroleum derivatives, solvents, thinners, highly concentrated or organic acids. Damage to pump may result. Consult Jabsco Chemical Resistance Table (available upon request from Jabsco) for proper body materials and impeller compounds. If corrosive fluids are handled, pump life will be prolonged if pump is flushed with water after each use or after each work day.
- PRESSURES** – Consult Head Capacity Table for recommended maximum for continuous operation. If pressures exceed those shown, consult the factory.
- TEMPERATURES**
 - Neoprene: 45° to 180°F (7° to 82°C)
 - Nitrile: 50° to 180°F (10° to 82°C)
- FREEZING WEATHER** – Drain unit by loosening end cover. The following anti-freeze compounds can be used without any adverse effects to the impeller: Atlas “Perma-guard”, Du Pont “Zerex” and “Telar”, Dow Chemical “Dow-guard” and Olin Mathison “Pyro Permanent”.
- NOTICE** – To avoid pump damage, do not use petroleum based anti-freeze compounds or rust inhibitors.
- SPARE PARTS** – To avoid costly shutdowns, keep a JABSCO Service Kit on hand.

SERVICE INSTRUCTIONS

DISASSEMBLY

1. Remove end cover screws, end cover and O-ring.
2. Remove impeller by grasping hub with water pump pliers.
3. Loosen cam screw and remove cam (clean off sealant).
4. Remove pulley or coupling and key from shaft.
5. Remove retaining ring which secures bearing/shaft assembly to pump body.
6. From impeller end of pump, press bearing and shaft assembly out of bearing bore. Remove slinger from shaft.
7. From drive end of pump, press the seal out of the seal bore.
8. If bearings or shaft need to be replaced, carefully insert two equal size slot screwdrivers between bearings 180° apart. Simultaneously twist screwdrivers in opposite directions to separate bearings. Continue to push bearings off of shaft taking care not to damage bearings or scratch shaft.
9. Remove snap ring that positions the bearings on the shaft.

NOTE: Inspect all parts for wear or damage and replace where necessary.

ASSEMBLY

1. Install bearing positioning snap ring on shaft.
2. Press bearings (one from each end of shaft) onto shaft and against positioning snap ring. Slide slinger onto impeller end of the shaft and position against raised shoulder near bearings.
3. Press seal (with lip pointing toward impeller bore) into seal bore in pump body. Lubricate seal lip with a small amount of grease.
4. Align impeller end of shaft with the seal and press shaft/bearing assembly into the bearing bore (push on bearing outer race). Install bearing retaining ring in retaining ring groove.
5. Apply a thin layer of sealant to screw threads and top of cam and install in body. Secure with cam screw.
6. Lubricate impeller bore with light coat of water pump grease and start impeller into bore with a rotary motion, until impeller screw engages slot in shaft, then push into bore.
7. Install O-ring and end cover. Secure with end cover screws.

HEAD CAPACITY TABLE

Model 2620-1001

Total Head		500 RPM		1160 RPM		1750 RPM		2100 RPM		2450 RPM		3000 RPM		3600 RPM	
Head in Feet (Meters)	PSI (kg/sq cm)	GPM (LPM)	HP	GPM (LPM)	HP	GPM (LPM)	HP	GPM (LPM)	HP	GPM (LPM)	HP	GPM (LPM)	HP	GPM (LPM)	HP
10 (3.0)	4.3 (0.3)	1.6 (6.0)	1/12	3.5 (13.3)	1/6	5.8 (22.0)	1/4	6.7 (25.4)	1/3	7.5 (28.4)	1/3	9.4 (35.6)	1/2	11.3 (42.8)	3/4
20 (6.1)	8.7 (0.6)	1.0 (3.8)	1/12	2.6 (9.8)	1/6	5.0 (18.9)	1/4	5.8 (22.0)	1/3	6.6 (25.0)	1/3	8.4 (31.8)	1/2	10.4 (39.4)	3/4
30 (9.1)	13.0 (0.9)	—	—	—	—	3.8 (14.4)	1/4	4.6 (17.4)	1/3	5.3 (20.0)	1/3	7.2 (27.3)	1/2	9.1 (34.4)	3/4
40 (12.2)	17.3 (1.2)	—	—	—	—	—	—	—	—	—	—	5.6 (21.0)	1/2	7.7 (29.2)	3/4
50 (15.2)	21.6 (1.5)	—	—	—	—	—	—	—	—	—	—	—	—	—	—

Capacities reduced by approximately 10% using Nitrile impeller at higher speeds and higher pressures.

NOTE: Progressively longer life may be expected as operating pressures and speeds are reduced. Factory Application Engineering assistance suggested for operation in light shaded area and recommended for heavy shaded area. Capacitor type motor recommended. Table shows approximate Head-Flow for new pump in U.S. gallons per minute and liters per minute.

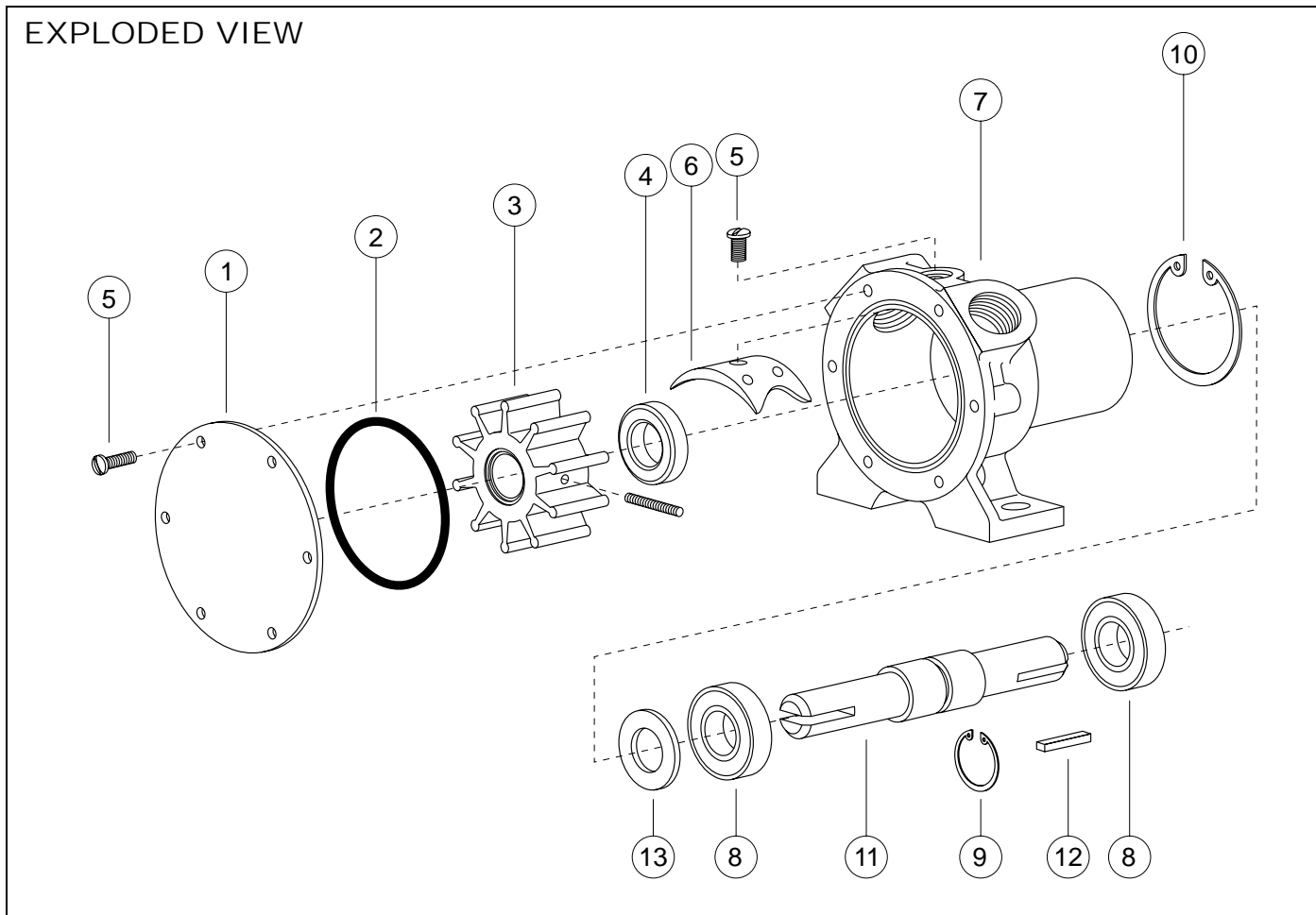

PARTS LIST

Key	Description	Qty. Req.	Part Number
1	End Cover	1	11830-0000
2	*O-Ring	1	18753-0125
3	*Impeller (with drive screw)	1	
	Neoprene		18673-0001
	Nitrile		18673-0003
4	*Seal (Shaft)	1	92700-0050
5	Screw Kit (7 each) for Cam and End Cover	1	18753-0121
6	Cam	1	2907-0001
7	Body	1	18753-0122
8	Ball Bearing	2	92600-0130
9	Retaining Ring (Bearing Positioner)	1	18715-0000
10	Retaining Ring (Bearing to Body)	1	18753-0123
11	Shaft	1	18753-0124
12	Key (Shaft Drive)	1	11847-0000
13	Slinger	1	879-0000
	Service Kit, Neoprene		90020-0001
	Service Kit, Nitrile		90020-0003

DIMENSIONAL DRAWING

Inches (Millimeters)

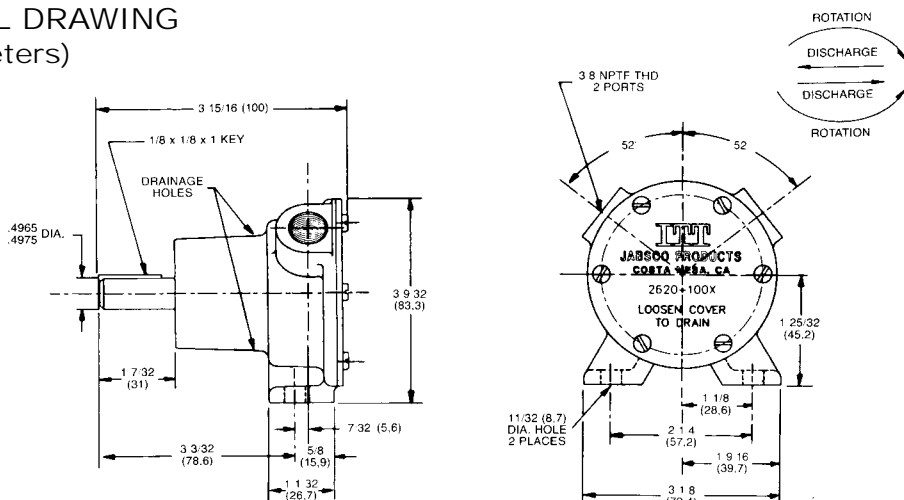

ONE YEAR LIMITED WARRANTY

A. LIMITED WARRANTY:

Jabsco warrants that at the time of shipment, the products manufactured by Jabsco and sold hereunder shall be in conformity with applicable written specifications and descriptions referred to or set forth herein, free from defects in material and workmanship, merchantable, and suitable for a particular purpose, provided such is implied by State law under the circumstances of this sale.

B. WARRANTY ADJUSTMENT:

1. Jabsco agrees to repair or furnish a replacement for, but not to remove or install, any product or component thereof which, within one (1) year from date of purchase, shall upon test and examination by Jabsco prove defective within the above warranty. Receipt verifying purchase date is required to obtain adjustment.
2. Buyer shall notify Jabsco of any defect within this warranty no later than ninety (90) days after the defect is discovered.
3. No product will be accepted for return or replacement without the prior written authorization of Jabsco. Upon such authorization, and in accordance with instructions from Jabsco, the product will be returned to Jabsco, shipping charges prepaid by Buyer. Products returned to Jabsco will be addressed as follows:

JABSCO
1485 Dale Way
Costa Mesa, California 92626-3998

Or to such alternate locations as may be designated on the product, its container, or this sheet.

Repair or replacement made under this warranty will be shipped prepaid to Buyer.

C. EXCLUSIONS FROM WARRANTY AND LIMITATION OF LIABILITY:

1. The foregoing warranty is limited solely as set forth herein and applies only for the period designated above.

2. ITT SHALL NOT BE LIABLE FOR ANY LOSS, DAMAGE, SPECIAL OR CONSEQUENTIAL DAMAGE OF ANY KIND, WHETHER BASED UPON WARRANTY, CONTRACT, NEGLIGENCE, OR STRICT LIABILITY ARISING IN CONNECTION WITH THE SALE, USE, OR REPAIR OF THE PRODUCT.
3. THE MAXIMUM LIABILITY OF ITT IN CONNECTION WITH THIS WARRANTY SHALL NOT IN ANY CASE EXCEED THE CONTRACT PRICE FOR THE PRODUCT CLAIMED TO BE DEFECTIVE OR UNSUITABLE.
4. This warranty does not extend to any product manufactured by Jabsco which has been subjected to misuse, neglect, accident, improper installation, or use in violation of instructions furnished by Jabsco.
5. This warranty does not extend to or apply to any unit which has been repaired or altered at any place other than Jabsco's factory, or by persons not expressly approved by Jabsco, nor to any unit the serial number, model number, or identification of which has been removed, defaced or changed.
6. Components manufactured by any supplier other than Jabsco shall bear only that warranty made by the manufacturer of that product.
7. This warranty applies to products defined as "consumer products" by the Consumer Product Warranties Act as from time to time amended.

D. CONSUMER RIGHTS:

This warranty gives you specific legal rights, and you may have other rights which vary from state to state. Some states do not allow exclusion or limitation of damages.

STANDARD WARRANTY: If the products manufactured and sold hereunder are not Consumer Products, the warranty extended to Buyer shall be as set forth in subparagraphs (A), (B), and (C), **EXCEPT THAT ALL EXPRESS OR IMPLIED WARRANTIES OR MERCHANTABILITY OR SUITABILITY FOR ANY PARTICULAR PURPOSE ARE EXCLUDED.**

Jabsco



ITT Industries
Engineered for life

PumpAgents.com - buy pumps and parts online

For technical advice or service please take your pump into your local pump service center.
To order pump or parts or for pricing please go to the following links :

[Jabsco Pumps Home >>](#)

[Jabsco Pumps stock list >>](#)