



**Models 18680-0920
 18680-0940**

ROTARY VANE PUMP

FEATURES

- Body:** Bronze
- Rotor:** Plastic - Liquid Crystal Polymer
- Vanes:** Plastic - Polyphenylene Sulfide
- Seal:** Lip Type, Nitrile
- Motor:** Permanent Magnet Type, Fully Enclosed, Stainless Steel Shaft
- Ports:** 1/2" Internal Pipe Threads
1" External Hose Barb
- Height:** 3-3/8" (86mm)
- Length:** 6-7/8" (175mm)
- Width:** 4-3/4" (121mm)
- Weight:** 5-1/2 lb (2.5 kg)

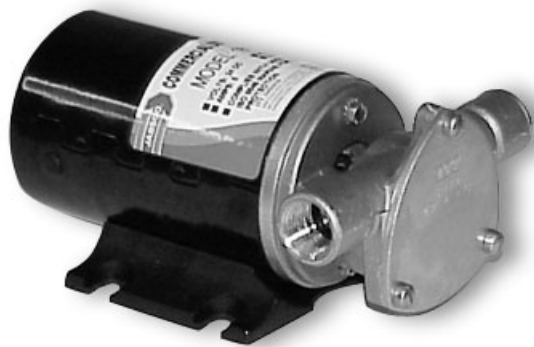

Models 18680-0920 & 18680-0940

VARIATIONS AVAILABLE

MODEL NO.	DESCRIPTION
18680-0920	12V DC
18680-0940	24V DC

⚠ WARNING Explosion hazard. Do not operate with rivets removed from motor case. Explosion resulting in personal injury, death or property damage can occur. Case openings must be sealed to avoid explosion and maintain ignition protected rating.

APPLICATIONS

The Jabsco Rotary Vane pump is ideal for transferring diesel fuel. The vectra rotor and vectra vanes are not affected by petroleum products. It is self-priming with a suction lift of up to three feet and can pump against a discharge head of up to thirty feet.

⚠ WARNING Explosion hazard. Do not pump volatile liquids with a flash point below 100°F (38°C). Doing so can cause an explosion or fire resulting in injury or death.

NOTE: No. 2 diesel fuel has a flash point of 125° (52°C) [ASTM, D-93].

INSTALLATION

The pump must be mounted in a dry location – the motor is not waterproof and must not be submerged. SELECTION OF A COOL, VENTILATED location will generally extend pump motor life. The unit can be mounted in any desired position. It is best to mount so that fluid dripping from a loose port connection will not

wet the motor. The pump head may be mounted at 90 degree increments on the motor to allow mounting as needed.

Motor meets USCG Electrical Standards (Title 33, Chapter I, Part 183; Subpart I) and ISD 8846 Marine for IGNITION PROTECTION on gasoline powered vessels. SEE WARNING NOTE.

PLUMBING CONNECTIONS

Pump ports have external 1" hose barb and internal 1/2" pipe threads. Use hose that does not kink when bent and with sufficient wall thickness to prevent collapse when used on suction side of pump. Ideally, hoses should be routed so that some fluid will be retained in pump body to wet the rotor and vanes. Wetting the rotor and vanes aids in priming. Use a strainer on the intake hose if debris or solids are present in the fluid being pumped. ALL HOSES MUST HAVE AIRTIGHT CONNECTIONS TO ENABLE FAST PRIMING.

HEAD CAPACITY TABLE

Total Head psi	Feet	Meters	Capacity	
			GPM	LPM
2.1	5	1.5	6.2	23.5
4.3	10	3.0	6.0	22.7
6.5	20	6.1	5.7	21.6
13.0	30	9.1	5.3	20.0

Table shows approximate Head-Flow for new pump.

ELECTRICAL SPECIFICATION

	<p>WARNING Explosion hazard. If pump is operated in an area containing flammable vapors, wire leads must be joined by insulated mechanical locking connectors. Loose or inadequate wire connections can spark resulting in an explosion. Property damage, injury or death can occur.</p>
---	---

Connect black wire to negative (-) terminal of battery. The orange wire should run to a properly sized (see electrical specification) overload protected switch or circuit breaker, with a wire from switch or breaker to positive (+) terminal of battery. Electrical circuit must be independent of all other accessories. A reversing switch may be used to reverse pump for intermittent duty cycles. Preferred motor rotation is clockwise looking at shaft end of motor. To prolong motor life, install pump so normal motor rotation is clockwise. Use proper wire size as determined by wire table elsewhere on this sheet.

MINIMUM WIRE SIZES

Wire Length Between Battery and Motor	12V	24V
1-10 ft. (3m)	#14	#16
11-20 ft. (6m)	#12	#16
21-30 ft. (9m)	#12	#14

NOTICE: To prevent motor damage, use only multi-strand copper wire in size recommended. **DO NOT** use ordinary lamp cord or other substitutes.

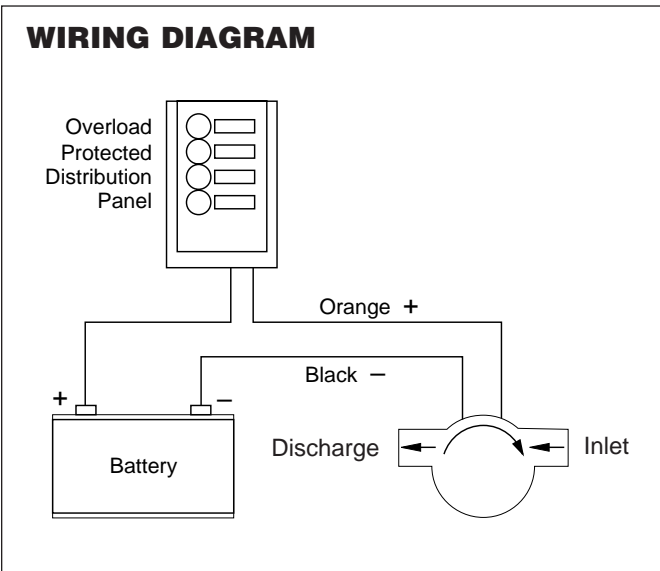

OPERATION

Rotary Vane pumps must NOT be run dry, as the pumped liquid is the lubricant for the rotor and vanes. Observe the outlet and shut off pump as soon as liquid stops flowing.

The pump cannot run against a closed outlet such as encountered when using a garden hose type shut-off nozzle. Pressure for normal operation should not exceed 20 feet of head (8.7 psi). Excessive pressures will cause fuse to blow.

Temperature of pumped liquid may be in the range of 45°-165°F (10°-78°C).

ELECTRICAL SPECIFICATION

Models	Amp Voltage	Amp Draw	Fuse Size
18680-0920	12V DC	8	15
18680-0940	24V DC	5	10

For technical advice or service please take your pump into your local pump service center.
To order pump or parts or for pricing please go to the following links :

[Jabsco Pumps Home >>](#)

[Jabsco Pumps stock list >>](#)