



Model 18660-0121

SELF-PRIMING PUMP

FEATURES

Motor:	Permanent magnet type, fully enclosed, stainless steel shaft.
Dimensions:	3" (76mm) high, 6-3/8" (162mm) long, 4-3/4" (120mm) wide
Weight:	4-1/2 lb (2 kg) (approx.)
Body:	Bronze
Impeller:	Jabco Neoprene compound
Seal:	Lip type
Ports:	1/2" Internal Pipe Threads 1" External Hose Barb Adapter for 3/4" External Garden Hose Thread included

Motor meets USCG Electrical Standards 183.410 and ISO 8846 MARINE for IGNITION PROTECTION on gasoline powered vessels.



Model 18660-0121

	<p>WARNING Explosion hazard. Do not operate with rivets removed from motor case. Explosion resulting in personal injury, death or property damage can occur. Case openings must be sealed to avoid explosion and maintain ignition protected rating.</p>
--	---

	<p>WARNING Explosion hazard. Do not pump gasoline, solvents, thinners or other flammable liquids. To do so can cause an explosion resulting in injury or death.</p>
--	--

APPLICATION

Use for bilge pumping, livewell circulation, washdown and general pumping requirements. If bilge water contains significant amount of oil, the standard impeller should be replaced with impeller No. 6303-0003, which is an oil-resistant nitrile material.

Pump has a dry prime suction lift of about 4 feet (1.2m) and a lift to 20 feet (6m) when primed. BE SURE SUCTION LINES ARE AIRTIGHT.

OPERATION

Flexible impeller pumps must *NOT* be run dry, as the pumped liquid is the lubricant for the impeller. Observe the outlet and shut off pump as soon as liquid stops flowing. An automatic level switch is convenient to control the pump.

The pump cannot run against a closed outlet such as encountered when using a garden hose type shut-off nozzle.

Pressure for normal operation should not exceed 20 feet of head (8.7 psi).

Temperature of pumped liquid may be in the range of 45° - 180°F (7° - 82°C).

	<p>WARNING Motor runs hot—about 180° is a normal temperature. Prolonged contact during operation may cause a burn.</p>
--	---

INSTALLATION

The pump must be mounted in a dry location – the motor is not waterproof and must not be submerged. **SELECTION OF A COOL, VENTILATED** location will generally extend pump motor life. The unit can be mounted in any desired position. It is best to mount so that water dripping from a loose port connection will not wet the motor. The pump head may be rotated 180° on the motor to change direction of flow.

PLUMBING CONNECTIONS

Pump ports have external 1" hose barb and internal 1/2" pipe threads. Also provided are two male port adapters to allow the attachment of 3/4" female garden hose fittings. Use hose that does not kink when bent and with sufficient wall thickness to prevent collapse when used on suction side of pump. Hoses should be routed so that some water will be retained in pump body to wet the impeller. Wetting the impeller aids in priming and extends impeller life. Use a strainer on the intake hose to stop trash and solids from going through the pump. All hoses must have air tight connections to enable faster priming.

ELECTRICAL CONNECTIONS

	<p>WARNING Explosion hazard. If pump is operated in an area containing flammable vapors, wire leads must be joined by insulated mechanical locking connectors. Loose or inadequate wire connections can spark resulting in an explosion. Property damage, injury or death can occur.</p>
--	---

Connect black wire to negative (-) terminal of battery. The orange wire should run to a fused overload protected switch or circuit breaker with a 15 amp rating, with a wire from switch or breaker to positive (+) terminal of battery. Electrical circuit must be independent of all other accessories. Failure to connect black wire to negative and orange wire to positive will result in backwards motor rotation and possible motor and pump damage. Correct motor rotation is clockwise looking at shaft end of motor. Use proper wire size as determined by wire table below. Should the fuse blow, replace with the same size fuse after determining reason for blown fuse.

HEAD-FLOW CHART

P.S.I.	Total Head		Capacity	
	Feet	Metres	GPM	LPM
2.1	5	1.5	6.3	23.8
4.3	10	3.0	5.4	20.4
6.5	15	4.6	4.2	15.9
8.7	20	6.1	2.8	10.6

Table shows approximate Head-Flow for new pump.

WIRING DIAGRAM

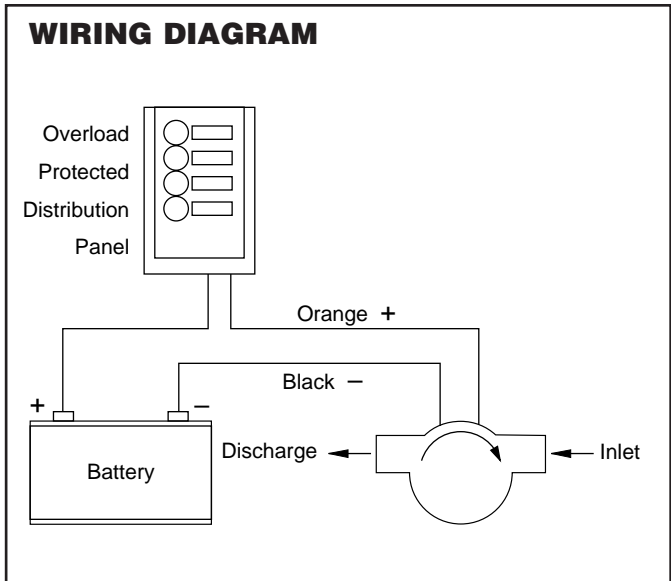

ELECTRICAL SPECIFICATIONS – MINIMUM WIRE SIZE

Model No.	VOLTAGE	AMP DRAW	FUSE SIZE	WIRE SIZE PER FEET OF RUN*			
				0'-10'	10'-20'	20'-30'	30'-40'
18660-0121	12 Vdc	8	15	#16 (1.5)	#16 (1.5)	#14 (2.5)	#14 (2.5)

* Length of run is combined length of positive and negative conductors from power source to pump and back to ground. Wire size is SAE gauge and metric (millimetres²).

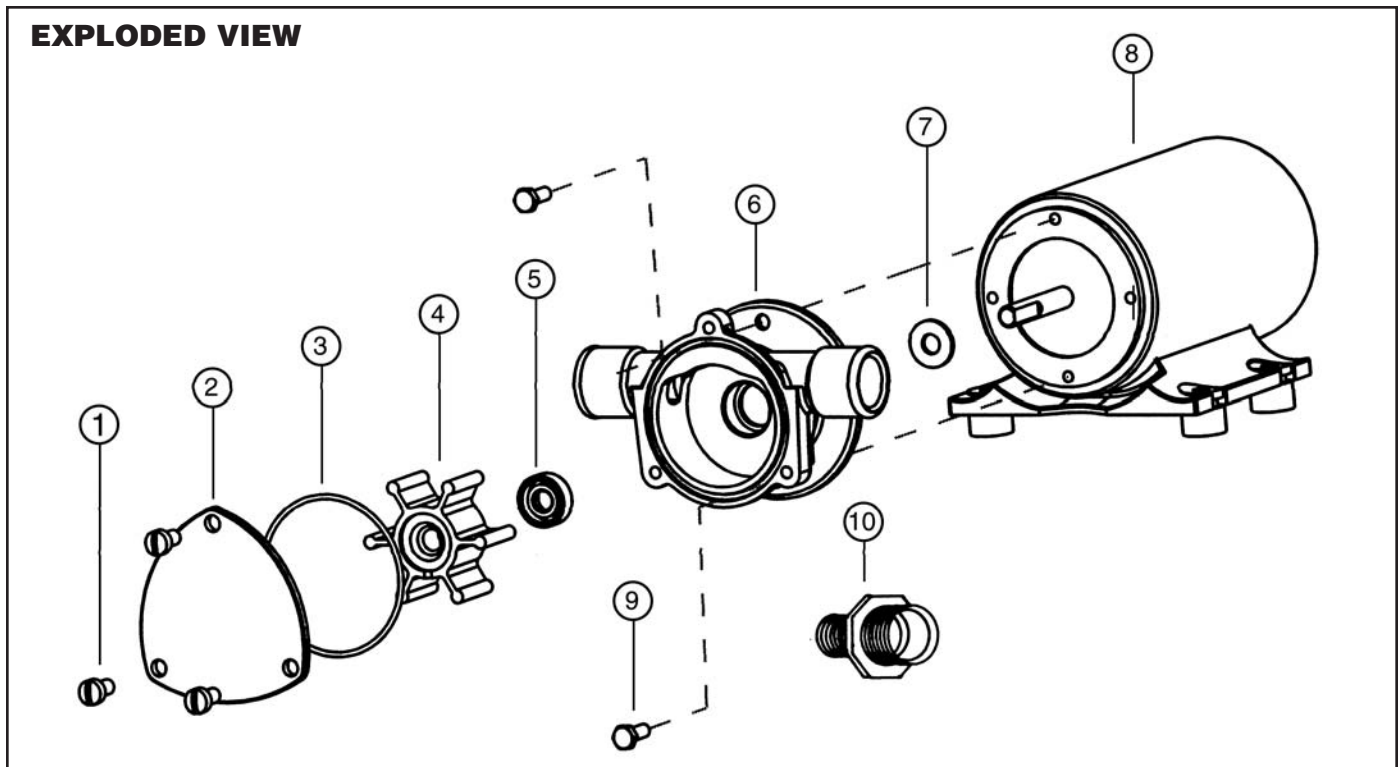

MAINTENANCE

Check wires and connections to be sure corrosion is not adding additional resistance to the motor circuit and causing a low voltage condition **at the motor. Low voltage can inhibit motor from starting and cause fuse to blow.** Full voltage should be available to prevent motor damage.

NOTICE: If pump is idle for extended periods, the impeller may stick to the pump body, preventing motor rotation and causing blown fuses. To correct, remove end cover and impeller, clean body and impeller, then lubricate with water or small amounts of grease before assembly.

If pump is to be in freezing temperatures, drain by loosening end cover screws.

A Service Kit, or at least spare impellers, should be carried aboard to be assured of pumping capability.

DISASSEMBLY

1. Remove end cover screws, end cover and O-ring.
2. Withdraw impeller.
3. Loosen and remove two slotted hex screws, which attach body to motor.
4. Tap body lightly between ports and remove body from motor.
5. With a 1/2" diameter dowel, push against the shaft seal from back (motor) side of the body to dislodge it from the seal bore.

NOTE: Do not tamper with or disassemble motor.

Key	Description	Qty. Req.	Part Number
1	Screw Kit (4/kit)	1	91004-0090
2	End Cover	1	18647-0000
3	O-Ring*	1	18753-0660
4	Impeller*	1	6303-0001
5	Seal*	1	18753-0384
6	Body†	1	18645-0000
7	Slinger	1	6342-0000
8	Motor 12V**	1	98012-0020
9	Screw (Pump to motor) (3/kit)	1	98019-0020
12	Port Adapter Kit (2/kit) Service Kit	1	18753-0103 90061-0006

† When replacing a pump body that uses a round end cover (3 hole pattern) it is necessary to replace the end cover, screws and replace the gasket with an O-Ring (order keys # 1, 2 & 3).

** For 24V and 32V replacement motors, consult the factory.

6303-0003 Oil resistant "Nitrile" Impeller available separately.

ASSEMBLY

1. Lubricate seal with water and position it in seal bore with lip, or hollowed-out side of seal, pointing towards the impeller bore. With a 1/2" diameter dowel, push against the shaft seal into its bore until it contacts the bottom.
2. Lubricate motor shaft and install body on motor.
3. Lubricate impeller bore and, aligning flat in impeller with flat on motor shaft, install impeller with clockwise rotary motion.
4. Install O-ring, end cover and screws.

DIMENSIONAL DRAWING
Inches (Millimetres)

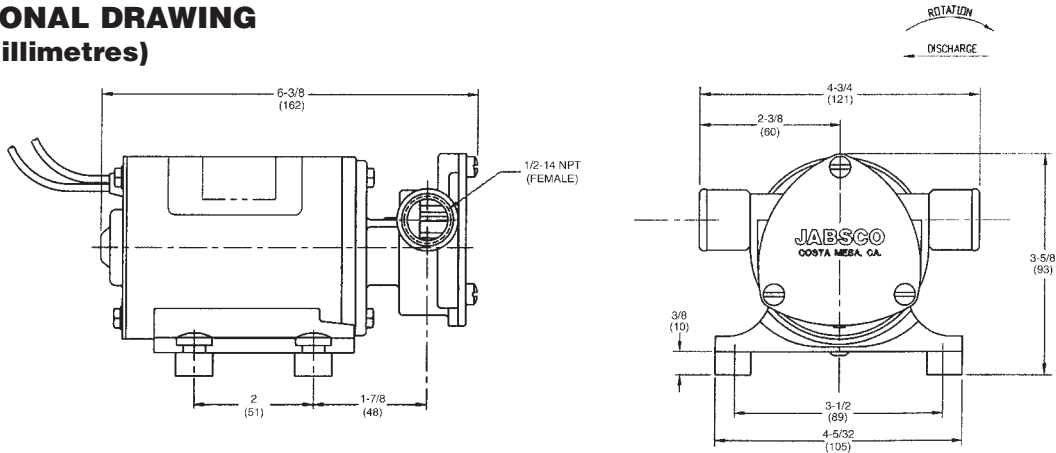

ONE YEAR LIMITED WARRANTY

A. LIMITED WARRANTY:

Jabsco warrants that at the time of shipment, the products manufactured by Jabsco and sold hereunder shall be in conformity with applicable written specifications and descriptions referred to or set forth herein, free from defects in material and workmanship, merchantable, and suitable for a particular purpose, provided such is implied by State law under the circumstances of this sale.

B. WARRANTY ADJUSTMENT:

1. Jabsco agrees to repair or furnish a replacement for, but not to remove or install, any product or component thereof which, within one (1) year from date of purchase, shall upon test and examination by Jabsco prove defective within the above warranty. Receipt verifying purchase date is required to obtain adjustment.
2. Buyer shall notify Jabsco of any defect within this warranty no later than ninety (90) days after the defect is discovered.
3. No product will be accepted for return or replacement without the prior written authorization of Jabsco. Upon such authorization, and in accordance with instructions from Jabsco, the product will be returned to Jabsco, shipping charges prepaid by Buyer. Products returned to Jabsco will be addressed as follows:

JABSCO
20 Icon
Foothill Ranch, California 92610

Or to such alternate locations as may be designated on the product, its container, or this sheet.

Repair or replacement made under this warranty will be shipped prepaid to Buyer.

C. EXCLUSIONS FROM WARRANTY AND LIMITATION OF LIABILITY:

1. The foregoing warranty is limited solely as set forth herein and applies only for the period designated above.

2. ITT SHALL NOT BE LIABLE FOR ANY LOSS, DAMAGE, SPECIAL OR CONSEQUENTIAL DAMAGE OF ANY KIND, WHETHER BASED UPON WARRANTY, CONTRACT, NEGLIGENCE, OR STRICT LIABILITY ARISING IN CONNECTION WITH THE SALE, USE, OR REPAIR OF THE PRODUCT.
3. THE MAXIMUM LIABILITY OF ITT IN CONNECTION WITH THIS WARRANTY SHALL NOT IN ANY CASE EXCEED THE CONTRACT PRICE FOR THE PRODUCT CLAIMED TO BE DEFECTIVE OR UNSUITABLE.
4. This warranty does not extend to any product manufactured by Jabsco which has been subjected to misuse, neglect, accident, improper installation, or use in violation of instructions furnished by Jabsco.
5. This warranty does not extend to or apply to any unit which has been repaired or altered at any place other than Jabsco's factory, or by persons not expressly approved by Jabsco, nor to any unit the serial number, model number, or identification of which has been removed, defaced or changed.
6. Components manufactured by any supplier other than Jabsco shall bear only that warranty made by the manufacturer of that product.
7. This warranty applies to products defined as "consumer products" by the Consumer Product Warranties Act as from time to time amended.

D. CONSUMER RIGHTS:

This warranty gives you specific legal rights, and you may have other rights which vary from state to state. Some states do not allow exclusion or limitation of damages.

STANDARD WARRANTY: If the products manufactured and sold hereunder are not Consumer Products, the warranty extended to Buyer shall be as set forth in subparagraphs (A), (B), and (C), **EXCEPT THAT ALL EXPRESS OR IMPLIED WARRANTIES OR MERCHANTABILITY OR SUITABILITY FOR ANY PARTICULAR PURPOSE ARE EXCLUDED.**

Jabsco



U.S.A.
Jabsco
20 Icon
Foothill Ranch, CA 92610-3000
Tel: 949.609.5106
Fax: 949.859.1254

UNITED KINGDOM
Jabsco
Bingley Road, Hoddesdon
Hertfordshire EN11 0BU
Tel: +44 (0) 1992 450145
Fax: +44 (0) 1992 467132

CANADA
Fluid Products Canada
55 Royal Road
Guelph, Ontario N1H 1T1
Tel: (519) 821.1900
Fax: (519) 821.2569

JAPAN
NHK Jabsco Company Ltd.
3-21-10, Shin-Yokohama
Kohoku-Ku, Yokohama, 222
Tel: 045.475.8906
Fax: 045.475.8908

GERMANY
Jabsco GmbH
Oststrasse 28
22840 Norderstedt
Tel: +49-40-53 53 73 -0
Fax: +49-40-53 53 73 -11