



Model 15170-Series

SANITARY PUMPS

FEATURES

Body:	Type 316 Stainless Steel
Impeller:	Jabsco Neoprene Compound
Seal:	Sanitary Carbon Face
Bearings:	Ball Bearing
Shaft:	Type 316 Stainless Steel
Ports:	2" Acme Threads, 2" Clamp
Weight:	34 lb (15,4 kg) approx.

PumpAgents.com - Click here for Pricing/Ordering

VARIATIONS

MODEL	DESCRIPTION
15170-0005	2" Acme Thread Ports
15170-0015	2" Clamp Ports

PERFORMANCE CHART

CAPACITY GPM	SUCTION & DISCHARGE LINE SIZE	PUMP SPEED	HP REQ.
65	1-1/2" ID	1100	1-1/2
90	2" ID	1525	2

Capacities and horsepower ratings are based on maximum head of 20 feet or 10 psi. Additional horsepower may be required when head pressures exceed 10 psi. Farm tank outlet inside diameter must be 1-3/8" with 1-1/2" hose to obtain capacities to 65 GPM and 1-7/8" with 2" hose for capacities to 90 GPM.

Table shows approximate capacity, in U.S. gallon per minute, for new pump with 20 feet of suction line. High starting torque motors are required. Pump starting torque in dry condition (no fluid in pump body) is 228 inch-pounds and in wet condition (fluid in pump body) is 168 inch-pounds. Impeller direction reversing torque in dry condition is 336 inch-pounds and in wet condition is 228 inch-pounds. Applications requiring continual reversal of impeller are not recommended.

This product is specifically designed for farm pick-up milk tanker trucks equipped with a remote drive. Jabsco pumps are also available pedestal mounted with capacities to 100 GPM. Contact factory for details.

- INSTALLATION** – Pump may be mounted in any position. The rotation of the pump shaft determines the location of the pump's intake and discharge ports; refer to dimensional drawing. Pump is normally assembled at factory for clockwise rotation, looking at end cover. If counterclockwise rotation is desired, follow steps 1, 2 & 3 of disassembly and steps 3, 4 & 5 of assembly instructions to change direction of impeller blade deflection under cam. Before use, rotate pump shaft in direction of operating rotation.
- DRIVE** – Belt or direct.
 - BELT:** Proper belt tension will insure optimum performance, bearing and belt life.
 - DIRECT:** Clearance should be left between drive shaft and pump shaft when installing coupling. Mount and align pump and drive shaft before tightening set screw. Flexible coupling is recommended. NOTE: Capacitor type motor is required.

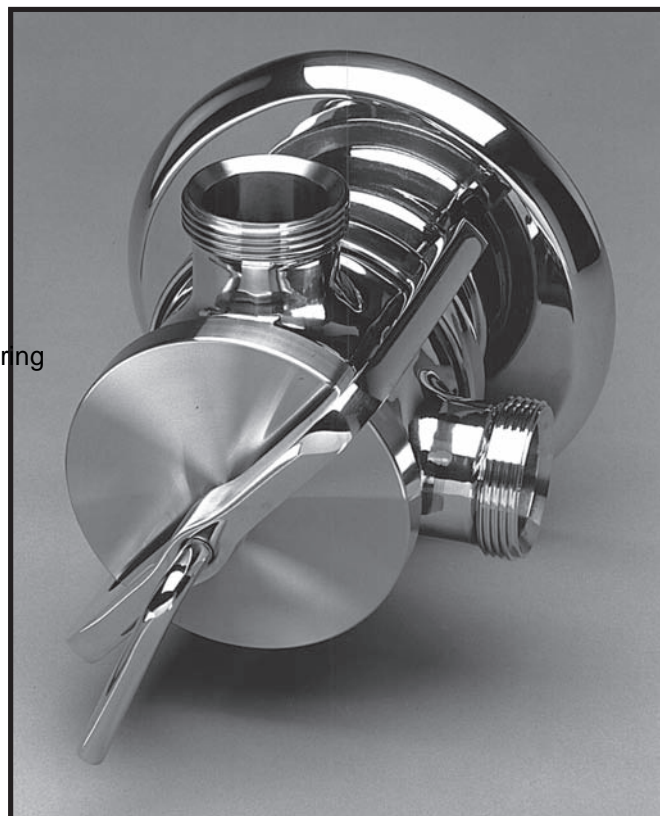

Model 15170-Series

WARNING



Injury hazard. Exposed pulleys and belts can cause injury. Install shield around pulleys and belts. Stay clear while machinery is operating.

- SELF-PRIMING** – Vertical lifts to 10 feet when dry. INTAKE LINES MUST BE AIRTIGHT to prevent product foaming and assure self-priming. Use noncollapsible hose.
- RUNNING DRY** – The impeller is lubricated by the product being pumped. CAUTION: DO NOT RUN DRY for more than 30 seconds. Lack of liquid will damage the impeller.
- NOTICE** – If pumping light fraction petroleum derivatives, solvents, thinners, highly concentrated or organic acids, consult Jabsco Chemical Resistance Table (which is available upon request from ITT Jabsco) for proper body materials and impeller compounds. If corrosive fluids are handled, pump life will be prolonged if pump is flushed with a neutralizing solution after each use or each work day.
- PRESSURES** – Consult performance chart. Contact factory for higher head applications.
- TEMPERATURES** – Standard impeller 40° to 150° F (4° to 65° C). Contact factory for impeller recommendation on applications outside this range. Other impeller compounds are available which may be utilized for certain applications at higher or lower temperatures.

EXPLODED VIEW

Model 15170-Series

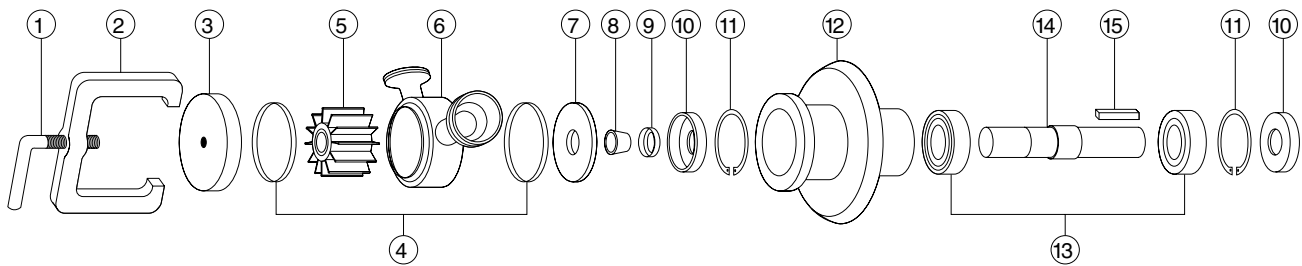

Key	Description	15170-0005/0015	Qty
1	Clamp Screw	18024-0000	1
2	Clamp	12927-0000	1
3	End Cover	10345-0001	1
*4	O-ring	92000-0030	2
*5	Impeller	8984-0005	1
6	Body (Acme)	15074-0061	1
	Body (CIP)	15074-0071	1
7	Wearplate	10346-0020	1
*8	Seal	9023-0000	1
9	Seal Collar	7866-0000	1
10	Bearing Seal	92702-0780	2
11	Retaining Ring (Hsg)	18726-0000	2
12	Bearing Hsg	12925-0000	1
13	Ball Bearing	18753-0007	2
14	Shaft	18023-0000	1
15	Key	9214-0000	1
10-15	Brg Hsg Assy Complete	18025-0000	
	Service Kit	90076-0015	

* Indicates parts supplied in Service Kit with addition of an Allen Wrench for seal adjustments.

SERVICE INSTRUCTIONS (ALL MODEL PUMPS)

ASSEMBLY AND DISASSEMBLY OF PUMP HEAD

Before using pump it should be disassembled and cleaned to remove any dust and dirt resulting from storage or shipping. Wash parts in standard cleaning solutions approved for handling stainless steel. Thoroughly rinse before reassembly. **DO NOT USE IODINE BASED SANITIZERS** as the iodine attacks the elastomer materials used in the impeller.

All parts have been expertly machined and polished. **HANDLE WITH CARE. DO NOT DROP OR MISHANDLE.**

DISASSEMBLY

1. Remove end cover clamp, end cover and O-ring.
2. Grasp pump ports and slide pump body and impeller from shaft.
3. Remove O-ring and then push the impeller from the pump body.
4. Remove wearplate from pump.
5. Slide seal assembly off the shaft. Do not damage the carbon seal face in handling. Do not loosen or remove seal collar except as noted below.

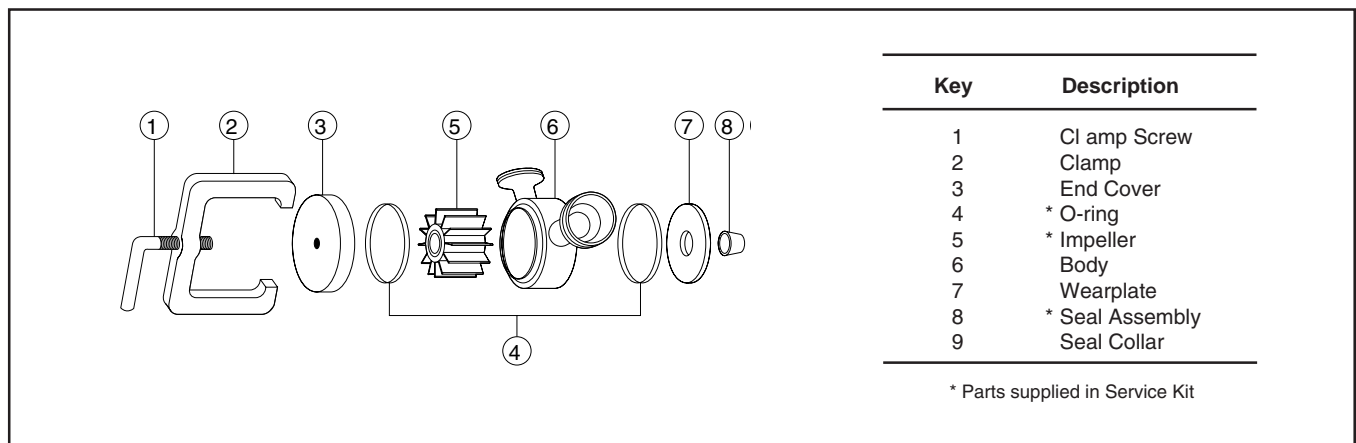

ASSEMBLY

1. Slide seal assembly onto shaft (carbon face toward pump head). Position as described in note below.
2. Replace wearplate. *BE SURE THAT FLAT SIDE IS TOWARD PUMP HEAD AND THE SIDE WITH THE RAISED BOSS IS TOWARD CARBON FACE OF SEAL ASSEMBLY.*
3. Lubricate bore of pump body with sanitary lubricate or suitable substitute and then replace impeller into pump body by twisting and pushing at same time.
4. Replace two O-rings on either side of body and install assembly on shaft. Impeller blades bent under cam should point in opposite direction to operational rotation.
5. Position end cover and then replace end cover clamp. **CLAMP SHOULD BE HAND TIGHTENED.** Do not use wrench or hammer.

NOTE: The seal collar is set at the factory to provide proper seal compression and should not require further adjustment.

For Seal Replacement:

With pump head disassembled; loosen two set screws on seal collar. Replace seal assembly on shaft and then install wearplate in *Reverse Position* with flat side toward seal. While holding wearplate in position against adaptor, push seal assembly and seal collar

against wearplate and tighten the two set screws in seal collar. Remove wearplate and replace to correct position with raised boss against carbon face of seal before assembling pump. **DO NOT ASSEMBLE PUMP WITH WEARPLATE IN REVERSE POSITION.**

DETAILED DISASSEMBLY AND ASSEMBLY OF BEARING HOUSING

DISASSEMBLY

1. Loosen set screws in seal collar. Remove seal collar from shaft.
2. Pry out bearing seals from each end of housing by inserting a thin screwdriver blade between O D of seal and housing bore. Remove housing retaining rings using retaining ring pliers.
3. Push on impeller drive end of shaft to remove shaft and bearing assembly from housing. Remove both parts.
4. Use arbor press to remove bearings from shaft. Remove small diameter spacer and retaining rings from shaft. Press outer bearing off shaft.

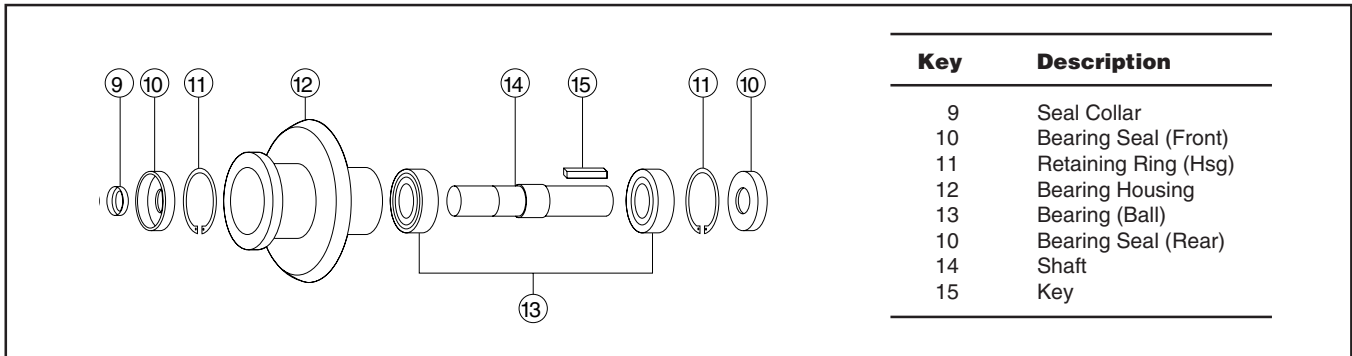

ASSEMBLY

1. Install inner retaining ring in housing.
2. Press inner bearing seal in housing with spring of lip seal facing outwards.
3. Support inner race of ball bearing and press each end of shaft through each bearing until bearing seats firmly against shoulder.
4. Liberally coat bearing race areas of bearings with a quality bearing grease. Do not pack entire area between bearings with grease or overheating will result. From rear of housing, insert shaft bearing
5. Install outer retaining ring in housing against bearing.
6. Press outer bearing seal into housing against retaining ring with spring of lip seal facing outwards.
7. Replace seal collar, with counter bore facing impeller end of shaft. Secure to shaft as described in seal adjustment instructions.

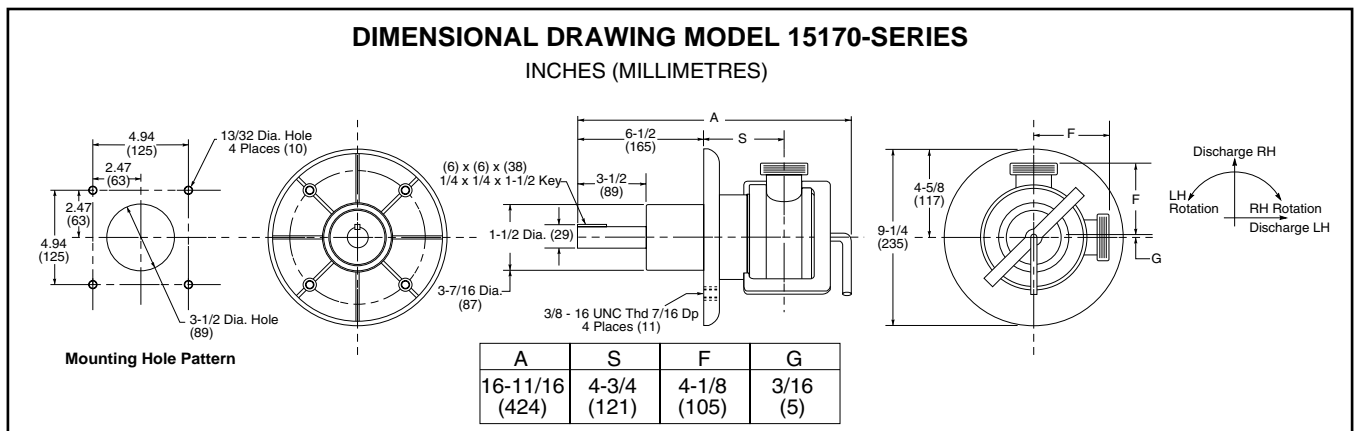

Jabsco



PumpAgents.com - buy pumps and parts online

THE PRODUCT DESCRIBED HEREIN IS SUBJECT TO THE JABSCO ONE YEAR LIMITED WARRANTY, WHICH IS AVAILABLE FOR YOUR INSPECTION UPON REQUEST.

For technical advice or service please take your pump into your local pump service center.
To order pump or parts or for pricing please go to the following links :

[Jabsco Pumps Home >>](#)

[Jabsco Pumps stock list >>](#)