



Model 12310-Series

SELF-PRIMING PUMP

FEATURES

Body:	Phenolic
Impeller:	Jabsco Neoprene, Nitrile Compound
Shaft Seal:	Lip Type
Shaft:	Stainless Steel (Supplied in Motor)
Ports:	3/4" External Thread Garden Hose 3/8" Internal Pipe Thread
Weight:	5-3/4 lb (2,6 kg)
Motor:	115 Vac (Intermittent Duty)

STANDARD MODELS

Model No.	Description
12310-0001	Neoprene Impeller
12310-0003	Nitrile Impeller



WARNING Explosion hazard. Motor can spark. Explosion and death can occur. Do not use where flammable vapors are present.

APPLICATION INFORMATION

Designed as a low cost pump with improved chemical resistance for chemical feeding, transfer, circulation, filtration, metering, filling line use and similar applications. Handles pure solutions, foaming liquids, and thin emulsions.

Because of the chemical, resistance of phenolic plastic and 316 stainless steel, these pumps are widely used to pump photo chemicals, plating solutions, lab solutions, pharmaceuticals, cosmetics, weak acids, alkalies, liquid fertilizers, insecticides, dyes, detergents, waxes and many more.

Limit to liquids with viscosity less than 50 SSU.

See the Jabsco "Chemical Resistance Table" in the Industrial Catalog which has been prepared as a guide to selection of pump material.

OPERATING INSTRUCTIONS

- 1.Installation:** Pump may be mounted in any position. The intake is located on the right when looking at the end cover.
- 2.Self-Priming:** Pump will produce suction lifts up to 7 feet when dry and to 15 feet when wetted. Be sure suction lines are airtight or pump will not self-prime.
- 3.Running Dry:** Unit depends on liquid pumped for lubrication. Do Not Run Dry for more than 30 seconds. Lack of liquid will damage the impeller and the plastic pump components.



Model 12310-Series

4. Notice: If pumping light fraction petroleum derivatives, solvents, thinners, highly concentrated or organic acids, consult Jabsco Chemical Resistance Table (which is available upon request from ITT Jabsco) for proper body materials and impeller compounds. If corrosive fluids are handled, pump life will be prolonged if pump is flushed with water after each use or after each work day.

5. Pressures: Consult Head Capacity Table for recommended maximum for continuous operation. If pressures exceed those shown, consult the factory.

6. Temperatures: Neoprene 45°–180°F, Nitrile 50°–180°F.

7. Spare Parts: A spare service kit should be kept on hand to eliminate excessive downtime.

HEAD CAPACITY TABLE

Total Head Capacity

psi	Kg. per Sq.Cm	Feet of Water	Meters of Water	GPM	Liters Per Min.
4.3	0,3	10	3,0	4.0	15,1
8.7	0,6	20	6,1	3.5	13,2
13.0	0,9	30	9,1	3.0	11,4
17.3	1,2	40	12,2	2.5	9,5

Flow rates are for water, capacity may be slightly reduced when handling heavy solids. Full load Amps – 7.2

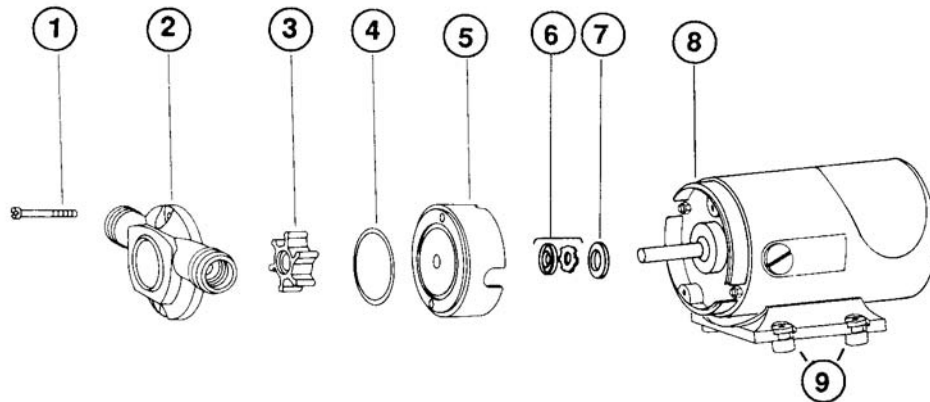
EXPLODED VIEW**PARTS LIST**

Key	Description	Qty. Req.	Model 12310-0001 Part Number
1	Screw (End Cover)	2	91023-0050
2	Body	1	12375-0000
3	*Impeller (Neoprene)	1	14792-0001
	*Impeller (Nitrile)	1	14792-0003
4	*O-Ring	1	92000-0750
5	Seal Housing	1	12314-0000
6	*Seal Assembly	1	1040-0000
7	Slinger	1	6342-0000
8	Motor	1	9195-0004
9	Grommet	4	92900-0120
	Replacement Pump Head		12377-0001
	Service Kit Neoprene		90158-0011
	Service Kit Nitrile		90158-0033
	Brush Assembly Replacement Kit		42626-0001

*Parts supplied in Service Kit

DIMENSIONAL DRAWING

Inches (Millimeters)

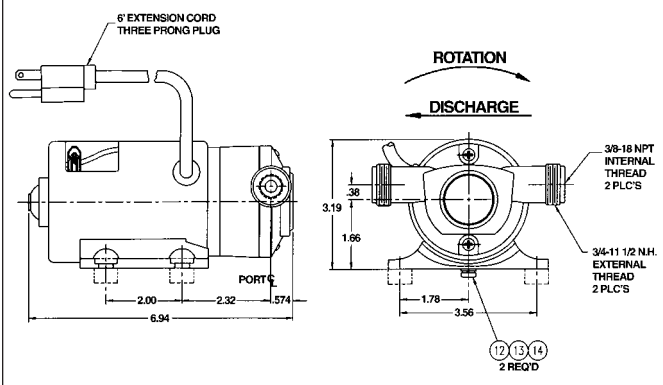
**SERVICE INSTRUCTIONS****DISASSEMBLY**

1. Remove screws, body, O-ring and seal housing.
 2. Withdraw impeller.
 3. Deform seal and remove from seal housing.
- NOTE: Do not tamper with or disassemble motor.

ASSEMBLY

1. Lubricate seal. Deform seal and install in cavity with open side of seal facing impeller.
2. Lubricate motor shaft and install seal housing on motor.
3. Lubricate impeller bore and, aligning flat in impeller with flat on motor shaft, install impeller.
4. Install O-ring, body and screws.

Jabsco



ITT Industries
Engineered for life

PumpAgents.com - buy pumps and parts online

THE PRODUCTS DESCRIBED HEREIN ARE
SUBJECT TO THE JABSCO ONE YEAR LIMITED
WARRANTY, WHICH IS AVAILABLE FOR YOUR
INSPECTION UPON REQUEST.

For technical advice or service please take your pump into your local pump service center.
To order pump or parts or for pricing please go to the following links :

[Jabsco Pumps Home >>](#)

[Jabsco Pumps stock list >>](#)