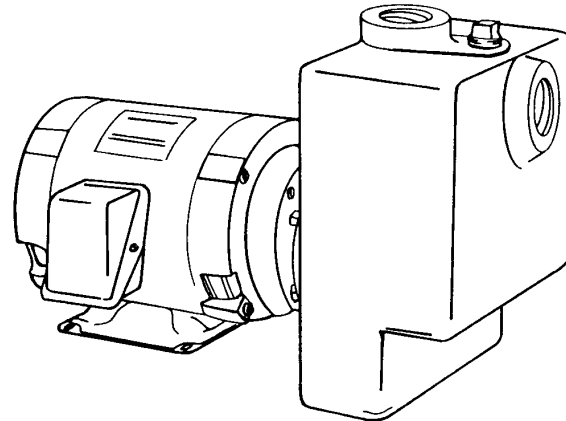

**SERIES: WG6-2**

SECTION	4A
PAGE	1
ISSUED	2/03
REPLACES	12/01

SELF-PRIMING CENTRIFUGAL PUMPS

3500RPM - 60Hz.
CAPACITIES TO 280GPM (17.7LPS)
HEADS TO 178 FEET (54.3M)

**FEATURES**

- CASING**
 Casing is close grain iron of 30,000 psi minimum tensile strength. Back pull-out design eliminates the need to disturb piping should the pump ever require service - the casing stays in the line.
- ENCLOSED BRONZE IMPELLER**
 Enclosed Bronze Impeller is of the latest hydraulic design for maximum efficiency. It is balanced for vibration-free operation. It is precision fit to shaft with key drive and cap screw lock.
- MECHANICAL SHAFT SEAL**
 Standard self-adjusting shaft seal for temperatures up to 225°F (107°C) and pressures to 150 psi (1034kpa). Ceramic seat and carbon seal face for long trouble-free service. Special seals are available for higher temperatures and fluids other than water.
- JM Type motors have NEMA standard mounting flange, extended steel shaft and dual bearings. These motors offer the advantage of quiet operation, controlled shaft deflection for longer seal life, and bearings sized to provide good service life. All motors are supplied by manufactures with national field service facilities.
- Flapper and check valves on the suction pipe are not required, but are recommended.
- BRONZE SHAFT SLEEVE**
 Gasketed and keyed hook-type sleeve protects shaft from wear and corrosion in seal area.

- FACTORY TESTED**

After careful assembly and inspection, **EVERY** pump is factory tested and will meet Hydraulic Institute standards.

MAXIMUM OPERATING CONDITIONS

TEMPERATURE (For Standard Buna-N Seal)	225°F (107°C)
INLET PRESSURE	100 PSI (690kpa)
CASING WORKING PRESSURE	200 PSI (1379kpa)

MOTOR INFORMATION

60 Hz - 3500 RPM - ODP

Three Phase: 5, 7-1/2 & 10 Hp. - 230/460 Volt

Voltages may differ from some suppliers. Consult factory.

Overload Protection: All motors must be installed with a magnetic starter which provides full 3-leg protection. Failure to use correct starter and overloads will void motor warranty.

MATERIALS OF CONSTRUCTION

PART	ALL IRON	BRONZE FITTED
Adapter	Cast Iron	Cast Iron
Casing	Cast Iron	Cast Iron
Casing Wear Ring	Steel	Bronze
Shaft	#316 Stainless	#316 Stainless
Impeller	Cast Iron	Bronze
Shaft Seal	Carbon-Ceramic S. Steel-Buna-N	Carbon-Ceramic S. Steel-Buna-N



PUMPS & SYSTEMS

A Crane Co. Company

SECTION	4A
PAGE	2
ISSUED	6/03
REPLACES	2/03



END SUCTION CENTRIFUGAL PUMPS

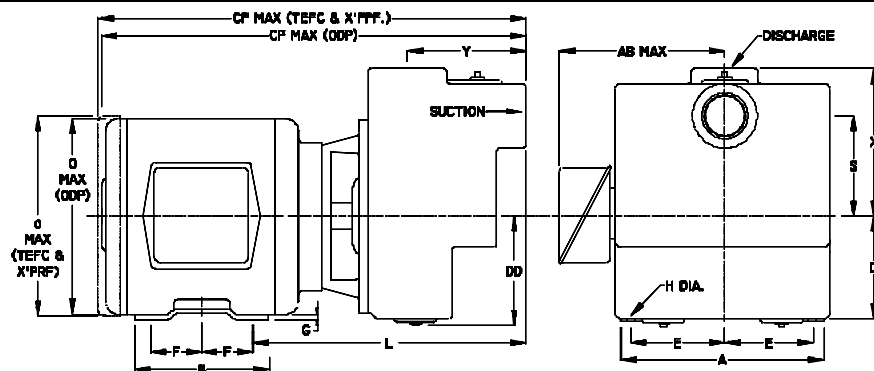
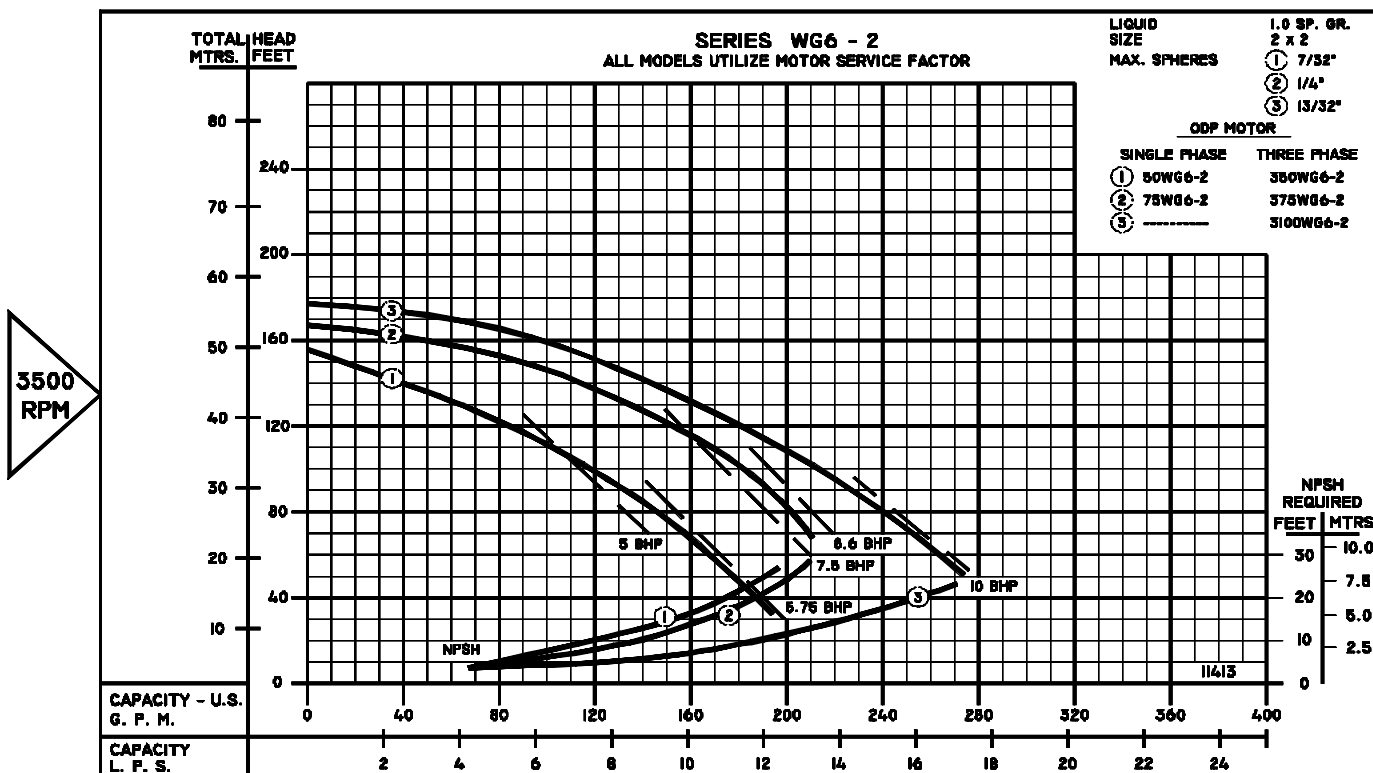

MODEL 3 PHASE	HP	Motor Frame Size	DISC. NPT	SUCT. NPT	DIMENSIONS IN INCHES														
					A	AB	B	CP	D	DD	E	F	G	H	L	O	S	X	Y
350WG6-2	5	182JM	2	2	8 ³ / ₄	9 ¹¹ / ₁₆	5 ³ / ₄	21 ¹¹ / ₁₆	4 ¹ / ₂	6 ¹ / ₂	3 ³ / ₄	2 ¹ / ₄	1 ¹ / ₂	13 ¹³ / ₃₂	14	9 ¹¹ / ₁₆	6 ⁵ / ₁₆	9	6 ¹ / ₁₆
375WG6-2	7 ¹ / ₂	184JM	2	2	8 ³ / ₄	9 ¹¹ / ₁₆	6 ³ / ₄	23 ¹¹ / ₁₆	4 ¹ / ₂	6 ¹ / ₂	3 ³ / ₄	2 ³ / ₄	1 ¹ / ₂	13 ¹³ / ₃₂	14	9 ¹¹ / ₁₆	6 ⁵ / ₁₆	9	6 ¹ / ₁₆
3100WG6-2	10	213JM	2	2	10 ³ / ₈	10 ⁷ / ₈	7 ³ / ₄	24 ³ / ₁₆	5 ¹ / ₄	6 ¹ / ₂	4 ¹ / ₄	2 ³ / ₄	5 ⁵ / ₈	13 ¹³ / ₃₂	14 ⁷ / ₈	11	6 ⁵ / ₁₆	9	6 ¹ / ₁₆

MODEL 3 PHASE	HP	Motor Frame Size	DISC. NPT inch	SUCT. NPT inch	DIMENSIONS IN MILLIMETERS														
					A	AB	B	CP	D	DD	E	F	G	H	L	O	S	X	Y
350WG6-2	5	182JM	2	2	222	246	146	551	114	165	95	57	13	10	356	246	160	229	154
375WG6-2	7 ¹ / ₂	184JM	2	2	222	246	171	602	114	165	95	70	13	10	356	246	160	229	154
3100WG6-2	10	213JM	2	2	264	276	197	614	133	165	108	70	16	10	378	279	160	229	154

Dimensions shown above are approximate maximum dimensions for standard pumps equipped with open drip-proof motors.

DO NOT USE FOR CONSTRUCTION PURPOSES. CERTIFIED DRAWINGS AVAILABLE ON REQUEST.



PUMPS & SYSTEMS

PumpAgents.com - buy pumps and parts online

CSPP-60

1 - MOTORS			
RPM & PHASE	PART NUMBER	HP	FRAME SIZE
OPEN DRIP PROOF			
3500 RPM Single Phase (ODP)	09902	5	184JM
	21850	7.5	213JM
3500 RPM Three Phase (ODP)	09906	5	182JM
	09907	7.5	184JM
	09999	10	213JM
TOTALLY ENCLOSED			
3500 RPM Three Phase (TEFC)	09950	5	184JM
	09951	7.5	213JM
	20000	10	215JM
EXPLOSION PROOF			
3500 RPM Three Phase (XP)	09954	5	184JM
	09955	7.5	213JM
	20001	10	215JM

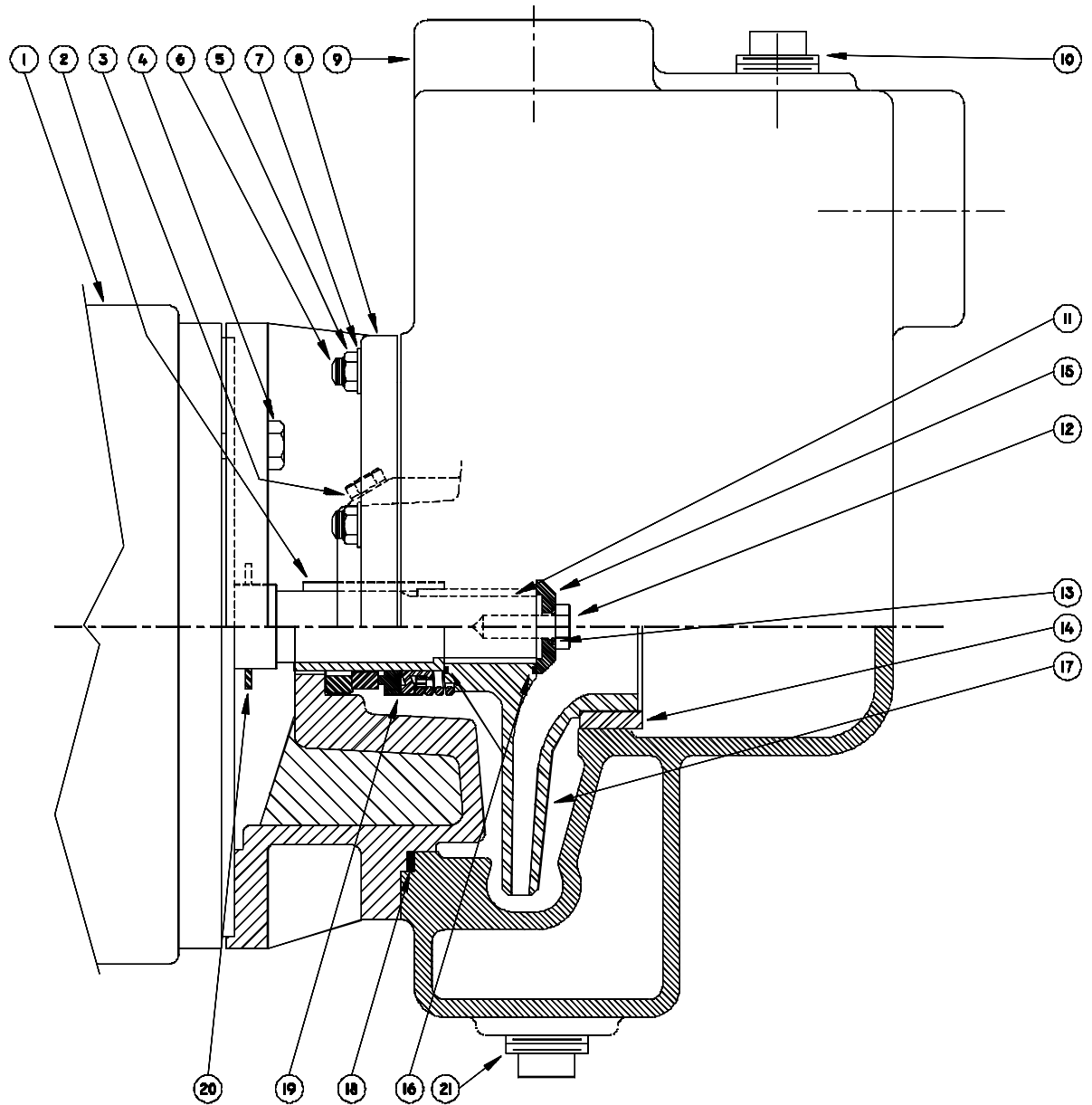

SERIES: WG6-2 SELF-PRIMING CENTRIFUGAL PUMPS

File: WG6-200.dwg

SYMBOL NUMBER	PART NUMBER	QUANTITY	DESCRIPTION
2	22063-C	1	Shaft Sleeve, Bronze
3	04236	1	Plug, 1/4-18 NPT - Bronze
4	01928	4	Cap Screw - 3/8-16 x 1" Lg. (9912 Adapter)
5	1-68-6	4	Cap Screw - 1/2-13 x 1-1/4" Lg. (9920 Adapter)
	15-23-6	8	Nut - 3/8-16
6	03075	8	Stud - 3/8-16 x 1-3/4" Lg.
7	01609-A	8	Washer
8	09912	1	Adapter, Iron, 182-184 JM Frames
* 9	09920	1	Adapter, Iron, 213-215 JM Frames
	23123-1	1	Casing Assy., Iron w/Brz. Wear ring - 5 & 7.5HP
	23123	1	Casing Assy., Iron - 10HP
10	02954	1	Plug, 1-11-1/2 NPT - Sq Hd., Bronze
11	23014	1	Key - 3/16 Sq. x 1-1/2" Lg.
12	1928-A	1	Cap Screw - 3/8-16 x 1 Lg., S.S.
13	22080	1	O-Ring - Buna N
	22081		O-Ring - Viton
	22082		O-Ring - Teflon
	22093		O-Ring - EPDM **
14	23265	1	Wear Ring, Bronze (23123-1 Casing Assy)
15	22105-C	1	Washer, Bronze - Impeller Retaining
16	22083	2	O-Ring - Buna N
	22084		O-Ring - Viton
	22085		O-Ring - Teflon
	22094		O-Ring - EPDM **
17	20420-6.06	1	Impeller, Bronze - 5HP
	09928-6.25	1	Impeller, Bronze - 7.5HP
	09929-6.25	1	Impeller, Bronze - 10HP
18	22099	1	O-Ring - Buna N
	23000		O-Ring - Viton
	23002		O-Ring - Teflon
	23001		O-Ring - EPDM **
19	09917	1	Mechanical Seal - Buna N
	09926		Mechanical Seal - Viton
	21271		Mechanical Seal - EPDM**
20	09918	1	Slinger Washer
21	00127	2	Plug, Sq. Hd., Iron

SYMBOL NUMBER	PART NUMBER	QUANTITY	DESCRIPTION
DIFFERING PARTS FOR ALL BRONZE CONSTRUCTION			
8	09912-B	1	Adapter, Brz., 182-184JM Frames
* 9	09920-B	1	Adapter, Brz., 213-215JM Frames
	23123-A-1	1	Casing Assy., Brz w/Brz. Wear Ring - 5 & 7.5HP
	23123-A	1	Casing, Bronze
12	03289	1	Cap Screw, 3/8-16 x 1" Lg., Bronze
DIFFERING PARTS FOR ALL IRON CONSTRUCTION			
2	22063-A	1	Shaft Sleeve, Stainless Steel
3	04236-A	1	Plug, 1/4-18 NPT, Stainless Steel
* 9	23123-B-1	1	Casing Assy, Iron w/steel wear ring - 5 & 7.5HP
10	26149	1	Plug 1-11-1/2 NPT - Sq Hd., Iron
14	23265-A	1	Wear Ring, Steel (23123-B-1 Casing Assy)
15	22105-A	1	Washer, Steel - Impeller Retaining
** 17	20420-A-6.06	1	Impeller, Iron - 5HP
	09928-A-6.25	1	Impeller, Iron - 7.5HP
	09929-A-6.25	1	Impeller, Iron - 10HP

** Size suffixes same as standard bronze impellers.

SERIES: WG6-2

* Casing Assy. Includes Symbol 14. 23270-1, -A-1, -B-1 (5 & 7.5HP) are complete casing assemblies consisting of symbols 6, 9, 10, 14 & 21. 23270, -A (10HP) are complete casing assemblies consisting of symbols 6, 9, 10 & 21.

For technical advice or service please take your pump into your local pump service center.
To order pump or parts or for pricing please go to the following links :

[Burks Pumps Home >>](#)

[Burks Pumps stock list >>](#)