

Little GIANT Pump Company

20G SERIES AUTOMATIC GRINDER



Features

- Powerful automatic 2HP, 3450 RPM, capacitor start, capacitor run, thermally protected motor to handle the demands of grinding domestic sewage
- Mechanical Float switch included. Piggyback plug on low-head models.
- Start/run components encased in pump housing; requires no control panel
- Oil-filled motor features upper and lower ball bearings, permanently lubricated for years of smooth, dependable operation
- Rugged cast-iron motor housing and volute are epoxy coated for corrosion resistance and durability
- Stainless steel cutter assembly designed to reduce solids to a slurry, for pumping through smaller diameter pipe than other types of systems
- Maximum flow 65 GPM
- Available in 200-208 or 230 volts, single phase
- Heavy duty 20' power cord
- Every unit is thoroughly tested before it ships from Little Giant Pump Company

The “Magnum™” Grinder Pumps Series have an exclusive cutter assembly that cuts sewage and stringy materials into tiny particles, eliminating roping and clogging that may occur in other pumps, producing a fine slurry that passes easily through the system. Compared to standard sewage pumps, this allows use of smaller diameter discharge pipes, smaller pumps and less electricity, reducing installation and operating costs.

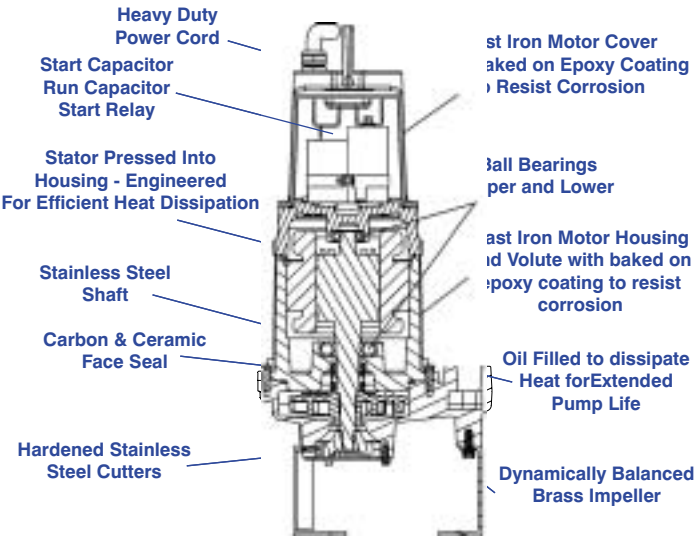

Because the Magnum™ Grinder pumps do not need to pass large solids, they can efficiently pump a greater distance in terms of the total dynamic head (TDH), a combination of the static (vertical) lift and the horizontal run of discharge piping, while maintaining the necessary flow rate to scour the discharge pipe to prevent clogging.

Little Giant Pump Co.

20G SERIES AUTOMATIC GRINDER

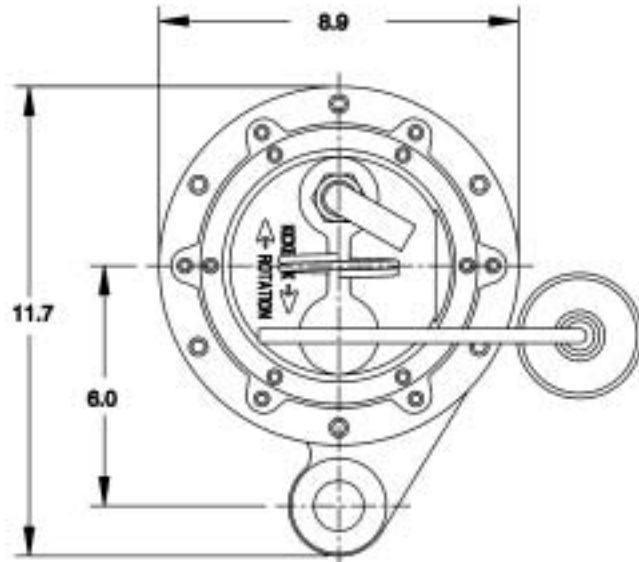
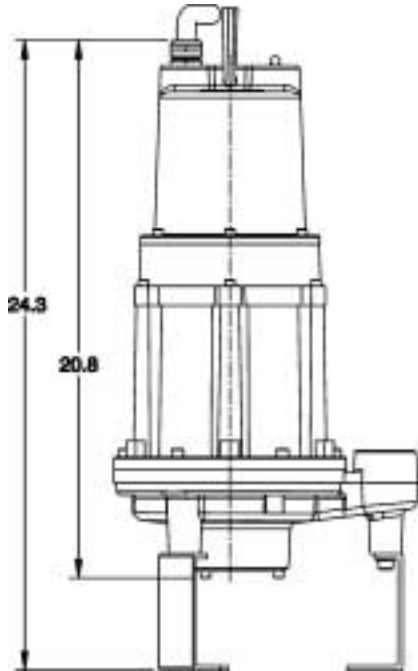

Specifications

MODEL NO.	ITEM NO.	LISTING	HP	VOLTS	Hz	FULL LOAD AMPS/WATTS	PERFORMANCE (GPM@HEAD)								SHUTOFF	P.S.I.	WEIGHT (lbs.)
							30'	40'	50'	60'	70'	80'	90'				
20GM-CIA-RFS	520510	UL/CSA	2	230	60	15/3370	—	65	58	50	42	30	16	95	41.13	117	
20GM-CIA-RFS	520535	UL/CSA	2	200-208	60	15/2925	65	57	53	45	35	23	—	90	38.96	117	
20GH-CIA-RFS	520610	UL/CSA	2	230	60	18/4060	—	65	58	52	44	35	—	110'	47.62	117	
20GH-CIA-RFS	520635	UL/CSA	2	200-208	60	20.0/4045	—	65	58	52	44	35	—	110'	47.62	117	

*20' Power cord on all models

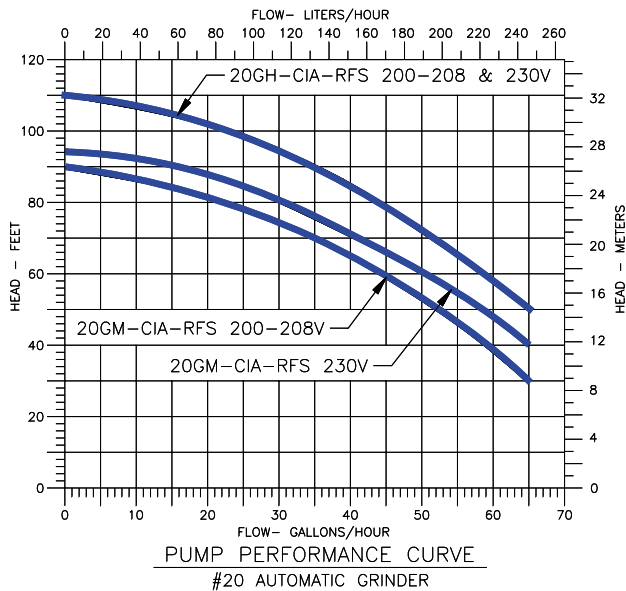

Construction

Motor Housing	Epoxy-Coated Cast Iron
Impeller	Bronze Vortex
Volute	Epoxy-Coated Cast Iron
Power Cord	12/3 SOW-A/SOW (20GH-CIA-RFS)
Power Cord	14/3 SOW-A/SOW (20GM-CIA-RFS)
Mechanical Shaft Seal	Carbon & Ceramic
Fasteners	Stainless Steel
Shaft	Stainless Steel
Bearings	Heavy duty continuously oil-lubricated upper and lower ball bearings
Cutter System	Hardened 440C Stainless Steel radial cutter and cutter ring
Discharge Size	1 1/4" FNPT

Little Giant Pump Co.
 PO Box 12010 Phone: 405.947.2511
 Okla. City, OK 73157 Fax: 405.228.1550
www.LittleGiantPump.com