

10S-CIA-SFS SERIES

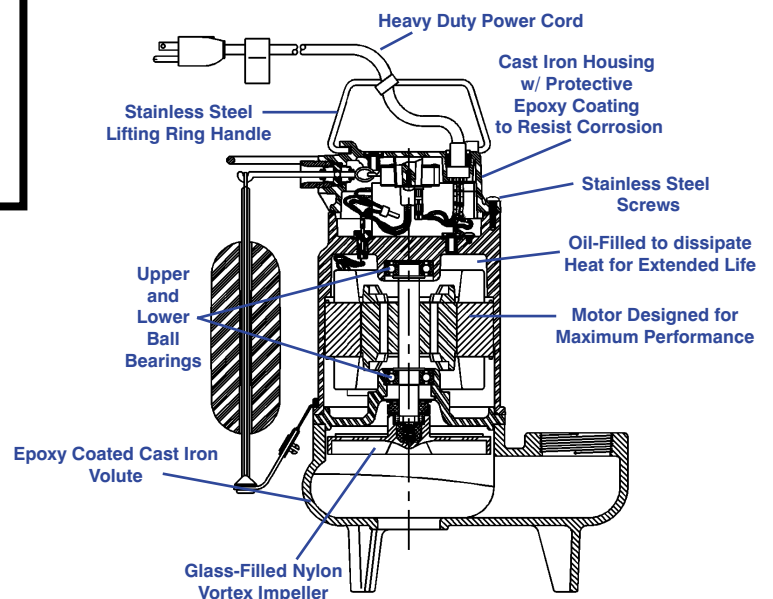

Features

- Handles liquids and solid waste materials up to 2" diameter
- Cast iron pump housing with protective epoxy coating for corrosion resistance
- Oil-filled motor housing for lifetime lubrication and rapid heat dissipation
- Stainless steel screws, bolts, handle and switch guard
- Mechanical seals (stainless steel spring, nitrile parts, carbon and ceramic faces)
- Thermal overload protection
- Automatic operation has 11 to 14 "On" level range and 5 to 8 "Off" level range with integral Snap-Action Float Switch
- PSC type motor with upper and lower ball bearings



The Model 10S-CIA-SFS sewage ejector pump offers greater capacities than the 9S Series. This pump handles liquids and solid materials up to 2" diameter. The 10S-CIA-SFS features a 2" discharge with a maximum lift of 20'.

Little Giant Pump Co.

10S-CIA-SFS SERIES

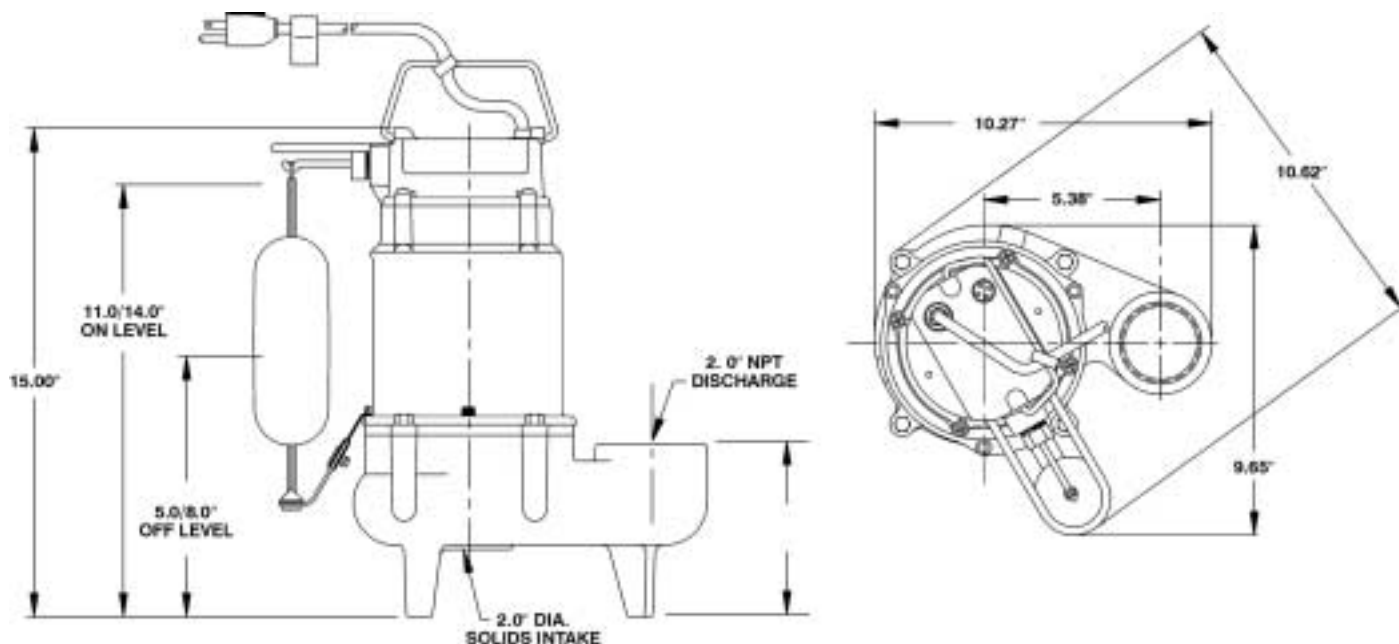

Specifications

MODEL NO.	ITEM NO.	LISTING	HP	VOLTS	SOLIDS SIZE (Dia. In.)	RUNNING AMPS/WATTS	PERFORMANCE (GPM @ HEAD)			SHUTOFF (Ft.)	PWR. CRD. (Ft.)	WEIGHT (Lbs.)	DIMENSIONS (H x L x W in.)
							5'	10'	15'				
10S-CIA-SFS	511550	UL/CSA	1/2	115	2	9.2/1086	110	85	45	20	8.7	10	46.0 15 x 10.3 x 9.65
10S-CIA-SFS	511555	UL/CSA	1/2	115	2	9.2/1086	110	85	45	20	8.7	25	46.0 15 x 10.3 x 9.65
10S-CIA-SFS	511565	UL/CSA	1/2	230	2	4.6/1086	110	85	45	20	8.7	25	47.0 15 x 10.3 x 9.65

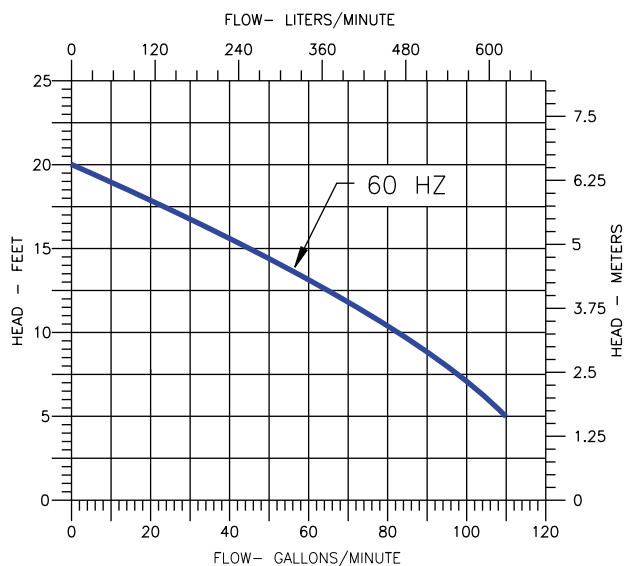

Construction

Motor Housing	Epoxy Coated Cast Iron
Impeller Material	Glass Filled Nylon
Impeller Type	Vortex
Volute	Epoxy Coated Cast Iron
Power Cord	16 - 3 SJTW
Mechanical Shaft Seal	Nitrile parts with carbon and ceramic faces
Fasteners	Stainless Steel
Shaft	Steel
Bearings	Upper & lower ball bearings



ISO 9001 CERTIFIED

Little Giant Pump Co.

PO Box 12010
Okla. City, OK 73157

Phone: 405.947.2511
Fax: 405.228.1550

www.LittleGiantPump.com

Form 995204 — 10/99