

PE-2F-PW SERIES

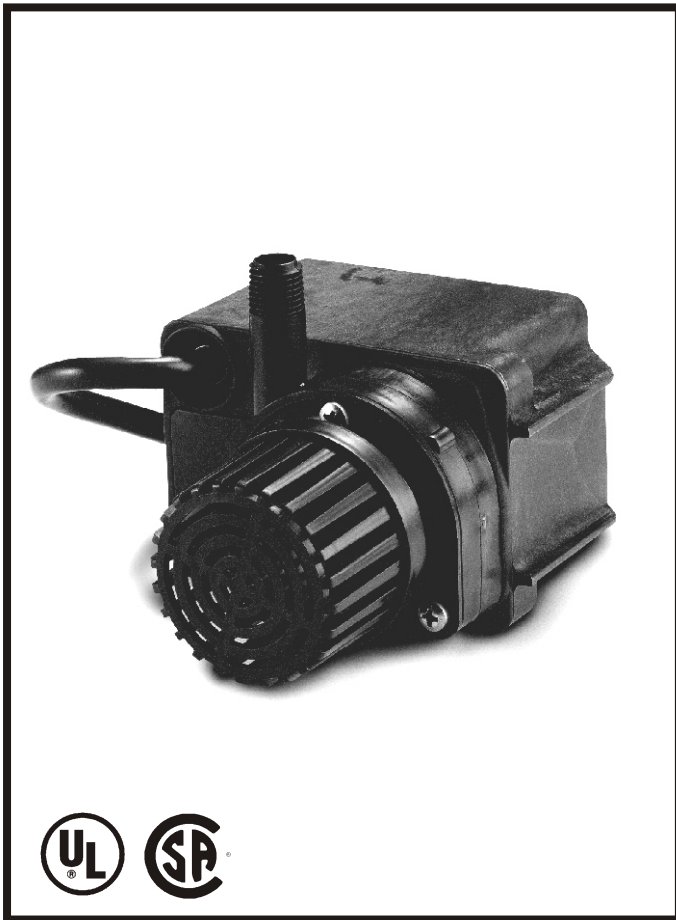

Features

- Environmentally safe, oil-less
- Energy efficient
- Corrosion resistant body
- 15' Cord
- 12.2' maximum lift
- 47 watts
- 1/4" MNPT Discharge
- For submersible use only
- Discharge accepts 1/2" I.D. tubing

Construction

- Motor — 1/40 HP Epoxy Encapsulated
- Intermittent Liquid Temp. up to — 120° F
- Intake — 3/8" FNPT with screen
- Discharge — 1/4" MNPT
- Housing — Glass-filled polyester
- Cover — Glass-filled polyester
- Volute — Nylon
- Impeller — Nylon
- Shaft Seal — Viton®
- Screen — Polypropylene

This pump features an epoxy-encapsulated motor, plastic housing and radial lip seal on the motor shaft. It provides enough power to effectively operate a water garden, statuary, or tabletop fountain. In fact, it may even be used in some harsh, industrial-type applications. This "potted" pump is usually more compact in size than an oil-filled pump of equal flow capacity.

PE-2F-PW SERIES

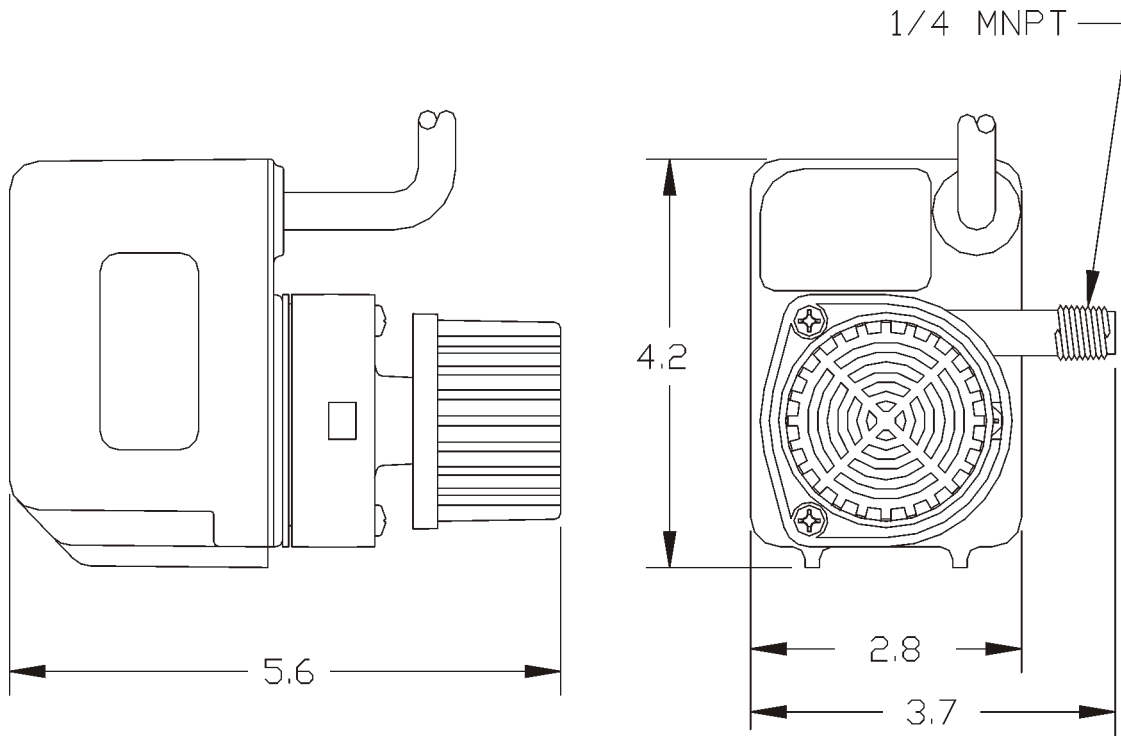

Specifications

Model No.	Item No.	Discharge	Listings	HP	Volts	Hertz	Amps	Watts	Performance (GPH @ Head)					Shut Off		Pwr. Cord (ft)	Weight (Lbs.)
									1'	3'	5'	8'	10'	Feet	PSI		
PE-2F-PW	566632	1/4" MNPT	UL/CSA	1/40	115	60	0.8	47	300	270	240	180	130	12.2	5.3	15	4.83

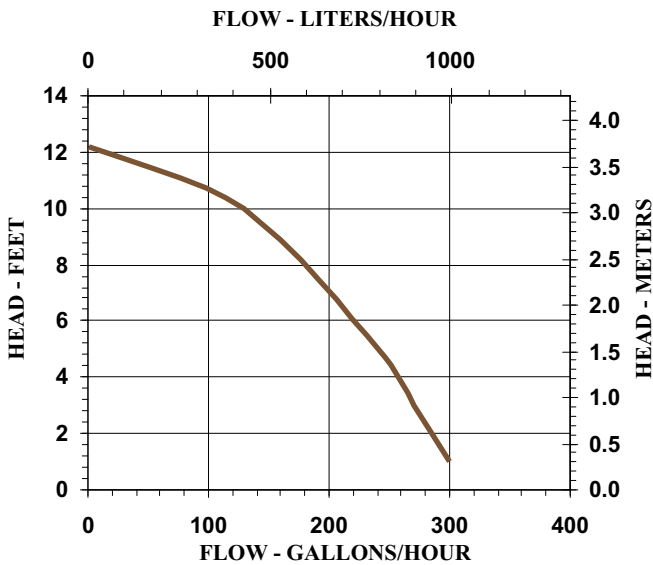

Replacement Parts

Volute	102375
Impeller	102703
Screen	118911
Gasket	102601