

Little GIANT[®] Pump Company

2EC-SPT



Features

- Permanently lubricated
- Epoxy coated cast aluminum housing
- Automatic, in-pan design
- Leak proof, rust proof, ABS plastic tank
- 1/4" MNPT discharge
- 11.8' max lift
- 6' power cord

Construction

- Motor — 1/40 HP
- Intermittent Liquid Temp. up to — 120° F
- Intake — N/A
- Discharge — 1/4" MNPT
- Housing — Epoxy coated cast aluminum
- Cover — Epoxy coated cast aluminum
- Volute — Nylon
- Impeller — Nylon
- Shaft Seal — Nitrile
- Screen — Polyethylene

Shallow pan automatic condensate removal pump that features an "on" level in 2-1/4" of water and "off" level in 1-1/2" of water. The pump is permanently lubricated and designed to maximize heat dissipation. This model includes a 1/2 gallon ABS tank or is ideal for in-pan placement for condensate removal.

Little Giant Pump Co.

2EC-SPT

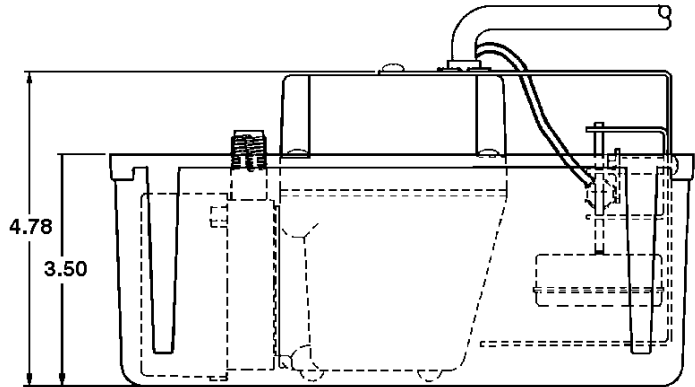
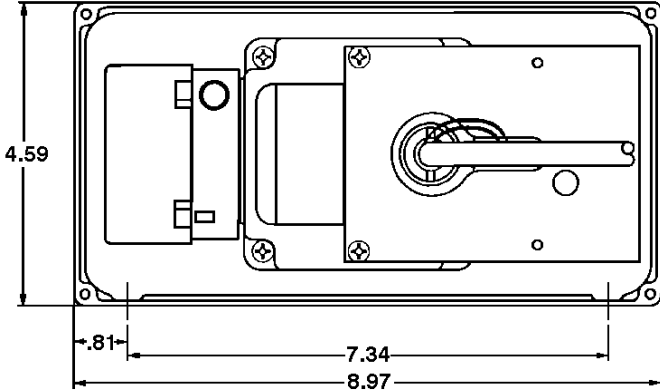

Specifications

Model No.	Item No.	Discharge Size	Listing(s)	HP	Volts	Hertz	Amps	Watts	Performance (GPH @ Head)				Shut Off		Pwr. Cord (ft)	Weight (Lbs.)
									1'	3'	5'	10'	Feet	PSI		
2EC-SPT	551015	1/4" MNPT		1/40	115	60	1.7	100	300	255	205	70	11.8	5.1	6	6.25
2EC-SPT	551025	1/4" MNPT		1/40	230	50/60	0.7	100	300	255	205	70	11.8	5.1	6	6.25

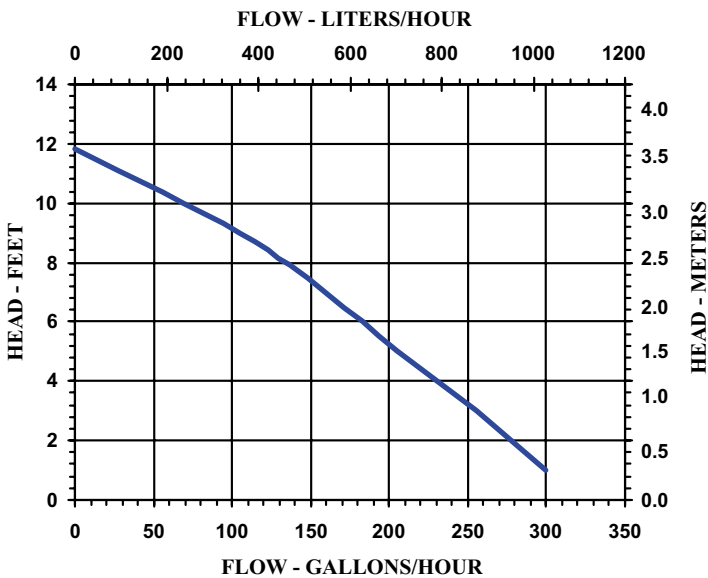

Replacement Parts

Tank	150102
Volute	102377
Impeller	102470
Screen	102909
Gasket	102601

Little Giant Pump Co.

PO Box 12010
Okla. City, OK 73157

Phone: 405.947.2511
Fax: 405.951.5674

www.LittleGiantPump.com

Form No. 995121 - 12/00