

CLOSE COUPLED TURBINE PUMPS

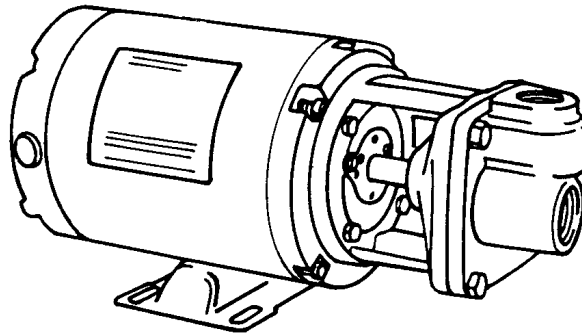

4CT - 1725 RPM - 60Hz.
CT - 3450 RPM - 60Hz.
 (See Individual curves for symbol number)

* MAXIMUM HEAD			
Symbol No.	H.P.	Catalog Number	
		1 - Phase	3 - Phase
1	1/2	5CT7M	35CT7M
2	3/4	7CT7M	37CT7M
3	1/3	3CT6M	33CT6M
4	1/2	5CT6M	35CT6M
5	3/4	7CT6M	37CT6M
6	1/3	3CT5M	33CT5M
7	1/2	5CT5M	35CT5M
8	1/4	24CT7M	
9	1/4	24CT6M	
10	1/2	5CT8M	35CT8M
11	3/4	7CT8M	37CT8M

* For Standard Pumps with ODP Motors

CT - 2900 RPM - 50Hz.
 (See Individual curves for symbol number)

MAXIMUM HEAD				
Symbol No.	H.P.	Catalog Number	PH	ENCL.
1	.8	L35CT7M	3	ODP
** 2	1.0	TL310CT7M	3	TEFC
3	1.125	L37CT7M	3	ODP
* 4	1.3	L10CT7M	1	ODP
5	.58	L33CT6M	3	ODP
6	.8	L35CT6M	3	ODP
** 7	1.0	TL310CT6M	3	TEFC
8	1.125	L37CT6M	3	ODP
9	.58	L33CT5M	3	ODP
10	.8	L35CT5M	3	ODP

* This pump is 115/230 Volt Single phase Only.

** This pump is available only with TEFC motor for 50 Hz use.

All of the pumps above are available with stuffing box.

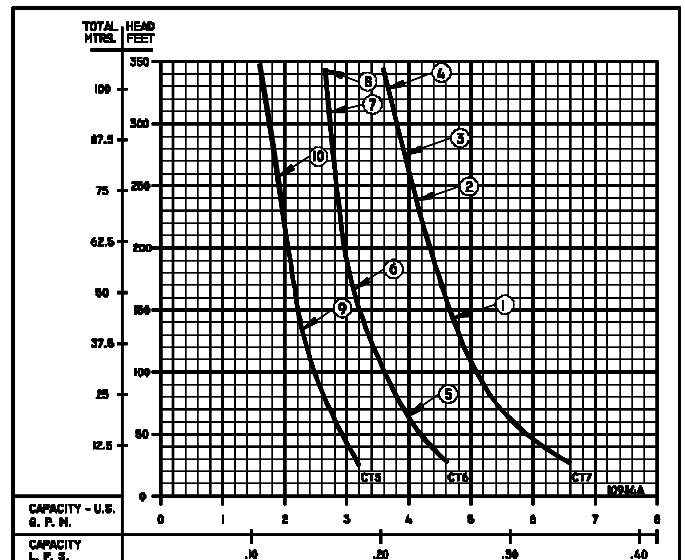
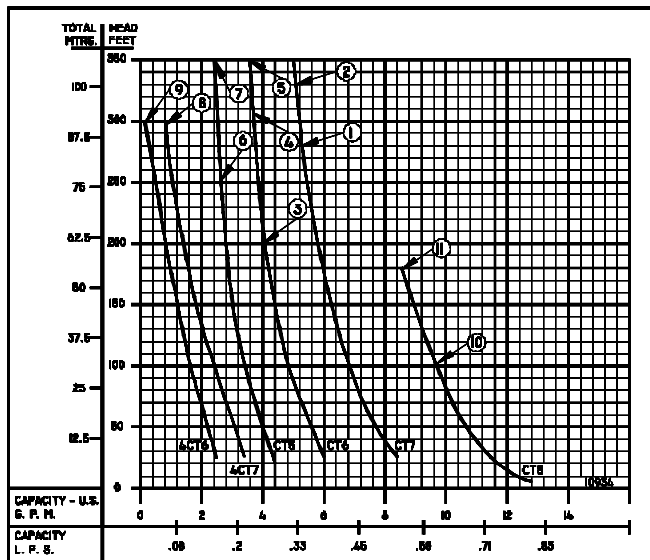

CLOSE COUPLED TURBINE PUMPS

60 HZ - PERFORMANCE & SELECTION CHART																				
Catalog Number		HP	Tappings		PSI FEET	TOTAL HEAD														
			Suct. NPT	Disch. NPT		8.6 20	17.2 40	26 60	43.3 100	54.1 125	64.9 150	75.8 175	86.6 200	97.4 225	108.3 250	119.1 275	130 300	140.1 325	151.6 350	
1-Phase	3-Phase				CAPACITY IN G.P.M.															
1750 RPM	24CT6M	---	1/4	1	1	2.4	2.2	1.9	1.6	1.4	1.2	1.0	0.8	0.6	0.5	0.4	0.3			
	24CT7M	---	1/4	1	1	3.4	3.1	2.8	2.3	2.1	1.8	1.6	1.4	1.2	1.0	0.8	0.7			
3450 RPM	3CT5M	33CT5M	1/3	1	1	4.2	4.0	3.8	3.4	3.2	3.0	2.9	2.8	2.7	2.6					
	5CT5M	35CT5M	1/2	1	1	4.2	4.0	3.8	3.4	3.2	3.0	2.9	2.8	2.7	2.6	2.6	2.5	2.4	2.4	
	3CT6M	33CT6M	1/3	1	1	6.0	5.7	5.3	4.8	4.6	4.4	4.3	4.2	4.0	3.9	3.8	3.7			
	5CT6M	35CT6M	1/2	1	1	6.0	5.7	5.3	4.8	4.6	4.4	4.3	4.2	4.0	3.9	3.8	3.7			
	7CT6M	37CT6M	3/4	1	1	6.0	5.7	5.3	4.8	4.6	4.4	4.3	4.2	4.0	3.9	3.8	3.7	3.7	3.6	
	5CT7M	35CT7M	1/2	1	1	8.3	7.8	7.4	6.8	6.5	6.2	6.0	5.8	5.5						
	7CT7M	37CT7M	3/4	1	1	8.3	7.8	7.4	6.8	6.5	6.2	6.0	5.8	5.5	5.5	5.3	5.2	5.1	5.0	
	5CT8M	35CT8M	1/2	1	1	11.7	11.0	10.5	9.7											
	7CT8M	37CT8M	3/4	1	1	11.7	11.0	10.5	9.7	9.3	8.9	8.5								

60 HZ - PERFORMANCE & SELECTION CHART																				
Catalog Number		HP	Tappings		kPa Meters	TOTAL HEAD														
			Suct. NPT (in)	Disch. NPT (in)		59 6.1	119 12.1	179 18.2	299 30.5	373 38.1	447 45.7	523 53.3	597 61	672 68.6	747 76.2	821 83.8	896 91.4	966 99.1	1045 106.6	
1-Phase	3-Phase				CAPACITY IN L.P.S.															
1750 RPM	24CT6M	---	1/4	1	1	0.15	0.13	0.11	0.10	0.08	0.07	0.06	0.05	0.03	0.03	0.02	0.01			
	24CT7M	---	1/4	1	1	0.21	0.19	0.17	0.14	0.13	0.11	0.10	0.08	0.07	0.06	0.05	0.04			
3450 RPM	3CT5M	33CT5M	1/3	1	1	0.26	0.25	0.23	0.21	0.20	0.18	0.18	0.17	0.17	0.16	0.16	0.15	0.15	0.15	
	5CT5M	35CT5M	1/2	1	1	0.26	0.25	0.23	0.21	0.20	0.18	0.18	0.17	0.17	0.16	0.16	0.15	0.15	0.15	
	3CT6M	33CT6M	1/3	1	1	0.37	0.35	0.33	0.30	0.29	0.27	0.27	0.26							
	5CT6M	35CT6M	1/2	1	1	0.37	0.35	0.33	0.30	0.29	0.27	0.27	0.26	0.25	0.24	0.23	0.23			
	7CT6M	37CT6M	3/4	1	1	0.37	0.35	0.33	0.30	0.29	0.27	0.27	0.26	0.25	0.24	0.23	0.23	0.23	0.23	0.22
	5CT7M	35CT7M	1/2	1	1	0.52	0.49	0.46	0.42	0.41	0.39	0.37	0.36	0.34						
	7CT7M	37CT7M	3/4	1	1	0.52	0.49	0.46	0.42	0.41	0.39	0.37	0.36	0.34	0.34	0.33	0.32	0.32	0.31	
	5CT8M	35CT8M	1/2	1	1	0.73	0.69	0.66	0.61											
	7CT8M	37CT8M	3/4	1	1	0.73	0.69	0.66	0.61	0.58	0.56	0.53								

NOTE: When pumping hot water over 180°F (82.2°C), check the NPSH available in the pumping system against the required pump NPSH shown on pump performance curves. Available NPSH must be greater than required NPSH.

FEATURES

MOTOR INFORMATION

Standard pump motors have open drip proof construction and are rated with jet pump service factors for continuous duty operation at all ratings shown.

Single phase motors are 115/230 volt, 60 Hz, capacitor start/induction run with built-in overload protection. Single phase motors 1/3, 1/2 & 3/4 HP are U.L. recognized.

Three phase motors require a magnetic type starter which provides full 3-leg overload protection. Failure to use the correct starter and overloads will void the warranty.

All three phase motors are 208-230/460 volt, 60/50Hz, 3450/2900 RPM.

FOR TEMPERATURES TO 500°F (260°C).

Series CT Pumps are available in a Jacketed Seal Cavity design for pumping hot oil, hot water and heat transfer fluids in common use in high temperature heating or cooling applications. This feature greatly extends seal life in high temperature applications. To order, add suffix "J" to pump catalog number for temperatures below 400°F (204°C) and add suffix "JK" to pump catalog number for temperatures over 400°F (204°C). Example: 5CT5MJ. See Section on High Temperature Pumps for more information.

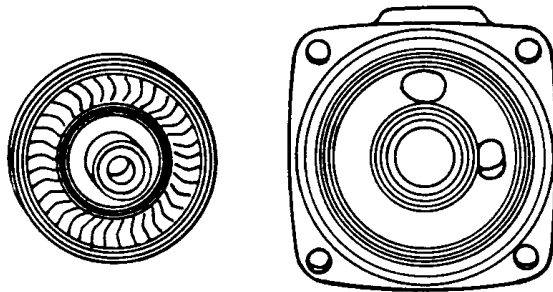

BURKS close coupled turbine pumps, Series CT, 3450 (60Hz) and 2900 (50Hz) R.P.M. and 4CT, 1725 R.P.M. are available for capacities up to 8 g.p.m. (0.50 L.P.S.)-pressures up to 150 p.s.i. (1034 kpa) and temperatures up to 225°F (107°C), come with standard mechanical shaft seal. Special shaft seals are available for higher temperatures and fluids other than water.

These compact turbine pumps are designed for pumping clear water and many other non-abrasive, lower viscosity liquids. They are especially engineered for boiler feed on steam process applications and will serve up to a 38 hp. boiler at a 3 to 1 safety factor. Available in bronze fitted as standard. All bronze or stainless steel construction also available. These pumps are recommended for many application requiring higher pressures and lower capacities.

BURKS is the only turbine pump with Life-Lok® External Impeller Adjustment feature that allows readjustment of impeller without disturbing piping, disassembling pump or replacing parts. Gives up to 40% longer service life than turbine pumps of other designs.

MATERIALS OF CONSTRUCTION			
PART	BRONZE FITTED	ALL BRONZE	STAINLESS STEEL
Frame	Cast Iron	Bronze	#316 Stainless
Impeller	Bronze (Monel Blades)	Bronze (Monel Blades)	#303 Stainless
Raceway	Bronze	Bronze	#303 Stainless
Shaft	#316 Stainless	#316 Stainless	#316 Stainless
Shaft Seal	Carbon-Ceramic S. Steel-Buna-N	Carbon-Ceramic S. Steel-Buna-N	Carbon-Ceramic S. Steel-Buna-N

MAXIMUM OPERATING CONDITIONS	
TEMPERATURE (For Standard Buna-N Seal)	225°F (107°C)
INLET PRESSURE	100 PSI (689kPa)
CASING WORKING PRESSURE	250 PSI (1724kPa)
VISCOSITY	200 SSU

DIMENSIONS

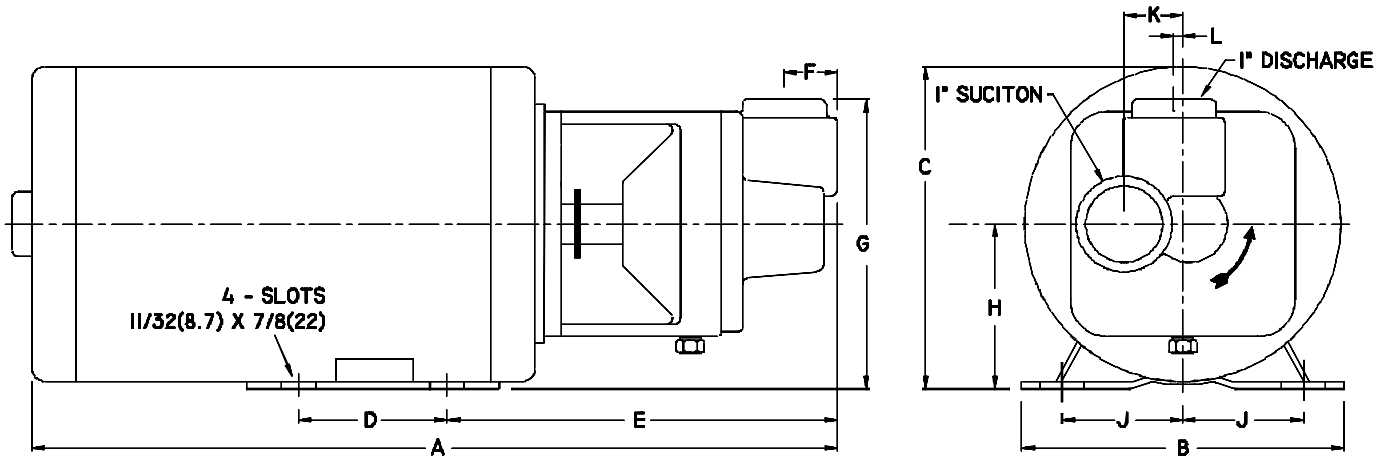

DIMENSIONS IN INCHES															
SERIES	HP	Tappings		1 PH A	3 PH A	B	C	D	E	F	G	H	J	K	L
		Disc. NPT	Suct. NPT												
4CT	1/4	1	1	16 ¹ / ₄	----	6 ¹ / ₂	6 ⁵ / ₈	3	7 ⁷ / ₈	1	5 ⁷ / ₈	3 ¹ / ₂	2 ⁷ / ₁₆	1 ⁵ / ₃₂	3 ³ / ₁₆
CT	1/3	1	1	16 ¹ / ₄	16 ¹ / ₄	6 ¹ / ₂	6 ⁵ / ₈	3	7 ⁷ / ₈	1	5 ⁷ / ₈	3 ¹ / ₂	2 ⁷ / ₁₆	1 ⁵ / ₃₂	3 ³ / ₁₆
	1/2	1	1	16 ¹ / ₄	16 ¹ / ₄	6 ¹ / ₂	6 ⁵ / ₈	3	7 ⁷ / ₈	1	5 ¹ / ₈	3 ¹ / ₂	2 ⁷ / ₁₆	1 ⁵ / ₃₂	3 ³ / ₁₆
	3/4	1	1	16 ¹ / ₄	16 ¹ / ₄	6 ¹ / ₂	6 ⁵ / ₈	3	7 ⁷ / ₈	1	5 ¹ / ₈	3 ¹ / ₂	2 ⁷ / ₁₆	1 ⁵ / ₃₂	3 ³ / ₁₆

DIMENSIONS IN MILLIMETERS															
SERIES	HP	Tappings		1 PH A	3 PH A	B	C	D	E	F	G	H	J	K	L
		Disc. NPT (in)	Suct. NPT (in)												
4CT	1/4	1	1	413	----	165	168	76	200	25	149	89	62	29	4.8
CT	1/3	1	1	413	413	165	168	76	200	25	149	89	62	29	4.8
	1/2	1	1	413	413	165	168	76	200	25	149	89	62	29	4.8
	3/4	1	1	413	413	165	168	76	200	25	149	89	62	29	4.8

Dimensions shown above are approximate maximum dimensions for standard pumps equipped with open drip-proof motors.

A strainer, approximately 20 mesh, should be installed on the suction side of the pump to prevent chips, scale or hard foreign particales from entering the pump and damaging the raceway and impeller.

CT SERIES CLOSE COUPLED TURBINE PUMPS

